

2

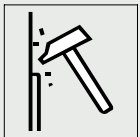

## Quinto



Operator manual  
Mode d'emploi Opérateur  
Operator Handbuch  
Operator handleiding  
Driftmanual  
Operatørhåndbok  
Betjeningsvejledning  
Operaattorin käsikirja  
Manual del operador  
Manual do operador  
Manuale per l'operatore  
Εγχειρίδιο χειρισμού  
Provozní příručka  
Instrukcja obsługi  
Manualul operatorului  
Руководство оператора  
Operatör kilavuzu  
操作手冊  
操作マニュアル  
동자 설명서



English  
Français  
Deutsch  
Nederlands  
Svenska

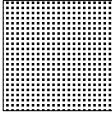

Norsk  
Dansk  
Suomi  
Español  
Português

Information  
Information  
Information  
Informatie  
Information



Informasjon  
Information  
Informaatio  
Información  
Informação

Table of contents  
Table des matières  
Inhaltsangabe  
Inhoudsopgave  
Innehållsförteckning



Innholdsfortegnelse  
Indholdsfortegnelse  
Sisällysluettelo  
Contenido  
Índice

Installation  
Installation  
Installation  
Installieren  
Installation



Installasjon  
Installation  
Asennus  
Instalar  
Instalação

Descaling  
Détartrage  
Entkalkung  
Ontkalken  
Avkalkning

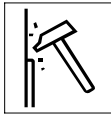

Rensing  
Afkalkning  
Kalkinpoisto  
Descalcificación  
Descalcificação

Programming  
Programmation  
Programmieren  
Programmeren  
Programmering



Programmering  
Programmering  
Ohjelmointi  
Programar  
Programação

Safety book  
Sommaire des sécurités  
Sicherheitsvorschriften  
Veiligheidsboek  
Säkerhetsföreskrifter



Sikkerhedsbok  
Sikkerhedsbog  
Turvallisuusohjeet  
Libro de seguridad  
Instruções de segurança

User manual  
Mode d'emploi Utilisateur  
Gebraucher Handbuch  
Gebruiksaanwijzing  
Användarmanual



Brukerhåndbok  
Brugsanvisning  
Käyttäjän käsikirja  
Manual del usuario  
Manual do operador

List of ingredients  
Liste des ingrédients  
Produktliste  
Ingrediëntenblad  
Ingredienslista

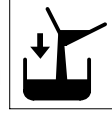

Ingrediensliste  
Ingrediens liste  
Ainesosaluettelo  
Lista de ingredientes  
Lista de ingredientes

Wait  
Patienter  
Warten  
Wachten  
Vänta



Vent  
Vent  
Odota  
Esperar  
Aguardar

Safety gloves  
Gants de sécurité  
Schutzhandschuh  
Veiligheidshandschoenen  
Skydds handskar



Hansker  
Sikkerheds handsker  
Suojahanskat  
Zapatos de seguridad  
Luvas de protecção

Safety goggles  
Lunettes de sécurité  
Schutzbrille  
Veiligheidsbril  
Skydds glasögon



Vernebriller  
Sikkerhedsbriller  
Suojalasit  
Gafas de seguridad  
Óculos de protecção

Hot liquid  
Liquide chaud  
Heiße Flüssigkeit  
Hete vloeistof  
Varma drycker



Varm væske  
Varm flydende  
Kuuma nestettä  
Líquido caliente  
Líquido quente

Counter  
Compteur  
Zähler  
Teller  
Räknare



Telleverk  
Tæller  
Laskin  
Contador  
Contador

Accessories  
Accessoires  
Zubehör  
Toebehoren  
Tillbehör

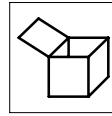

Tilbehør  
Valgbar  
Lisälaitteet  
Accesorios  
Acessórios

Optional  
Option  
Produktliste  
Optioneel  
Tillval

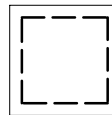

Valgfri  
Tilbehør  
Valinnainen  
Opcional  
Opcional

it : Per la Sua lingua consultare la fine di questo documento.  
el : Στην αναδιπλωμένη σελίδα, στο τέλος του εντύπου, μπορείτε να κοιτάξετε για τους όρους στη γλώσσα σας.  
cz : Volba jazyka je popsána na konci následující stránky tohoto návodu.  
pl : Szukaj swojego języka na ostatnich stronach dokumentu.  
ro : Citiți pentru limba dvs pagina atașată la spatele acestui document.  
ru : Вкладыш на Вашем языке в конце этого документа.  
tr : Diliniz için arkadaki kattı sayfaya bakınız.  
ch : 查看背頁的所屬語文  
jp : 各言語についてはこの説明書の最後のページをご参照ください。  
kor : 자료의 뒷면 접은페이지에서 해당언어를 참조 하시오





Installation  
Installation  
Installation  
Installieren  
Installation

Installasjon  
Installation  
Asennus  
Instalar  
Instalação

Installazione  
Εγκατάσταση  
Instalace  
Instalacja  
Operare

Установка  
Yerleştirme  
安裝  
設置  
설치

1



Programming  
Programmation  
Programmieren  
Programmeren  
Programmering

Programmering  
Programmering  
Ohjelmointi  
Programar  
Programação

Programmazione  
Προγραμματισμός  
λειτουργίας  
Programování  
Programowanie  
Programare

Программирование  
Programlama  
程式  
プログラミング  
프로그램

7

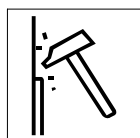

Descaling  
Détartrage  
Entkalkung  
Ontkalken  
Avkalkning

Rensing  
Afkalkning  
Kalkinpoisto  
Descalcificación  
Descalcificação

Decalcificazione  
Αφαλάτωση  
Odvápnění  
Odkamienianie  
Decalcarizare

уистка от накипи  
Kireçten arındırma  
除垢  
デスケール  
스케일 청소

21

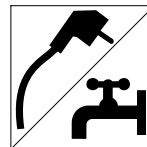

Installation  
Installation  
Installation  
Installeren  
Installation

Installasjon  
Installation  
Asennus  
Instalar  
Instalação

Installazione  
Εγκατάσταση  
Instalace  
Instalacja  
Operare

Установка  
Yerleştirme  
内容目録  
目次  
목차

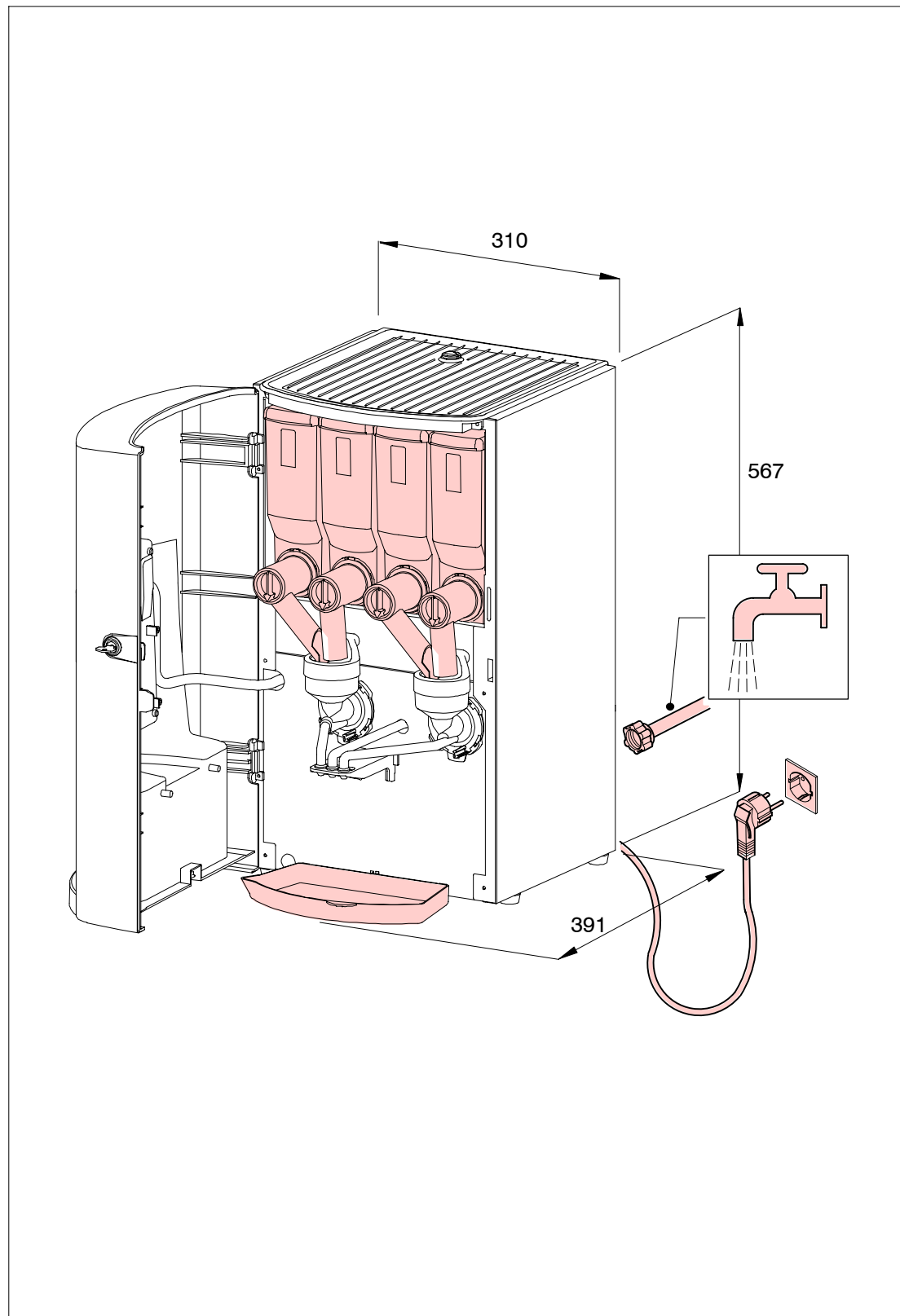

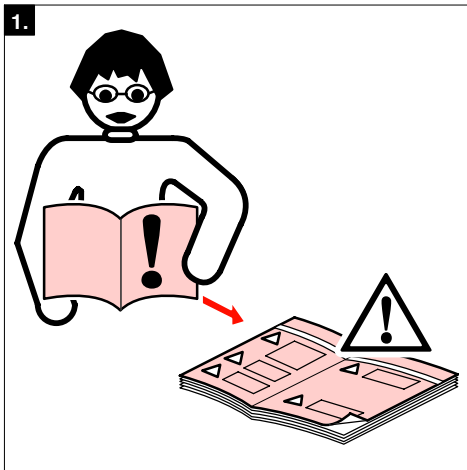

700.403.347

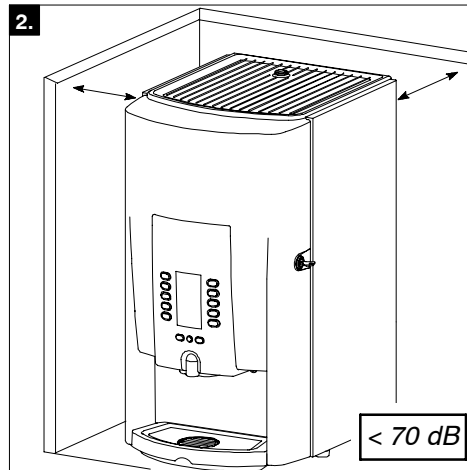

700.403.347

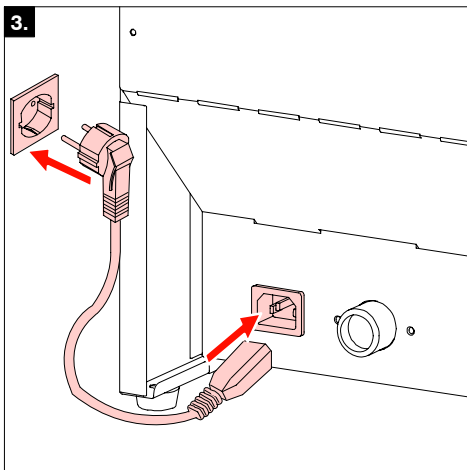

700.403.347

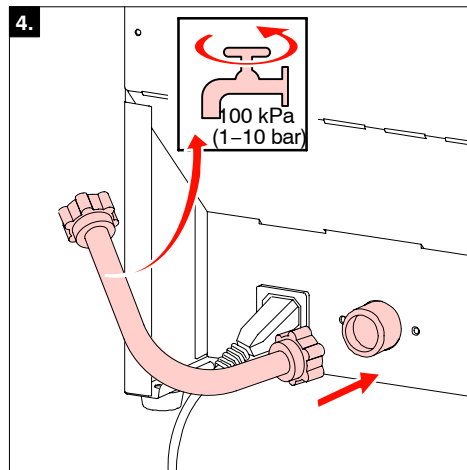

700.403.347

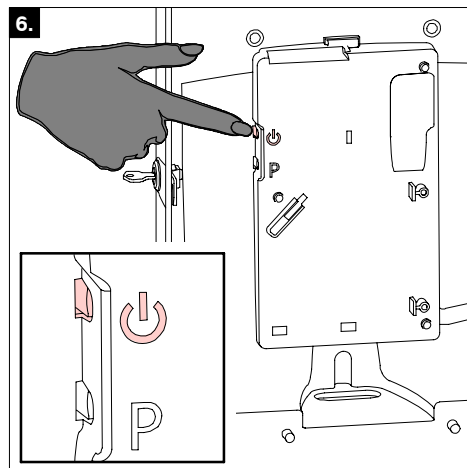
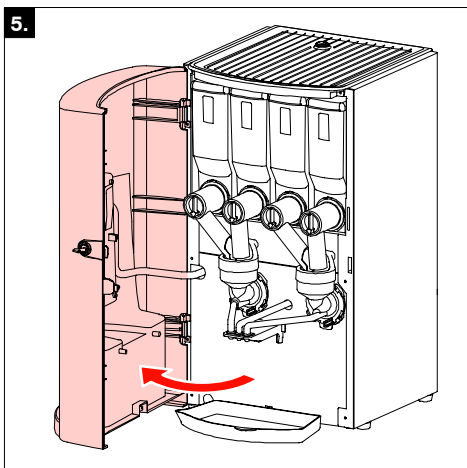

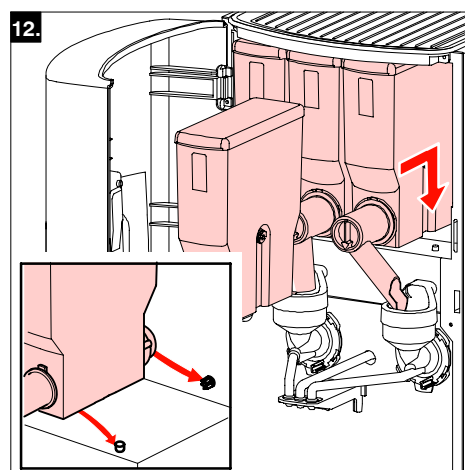
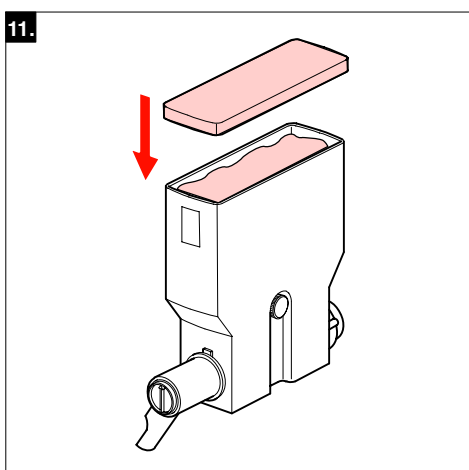
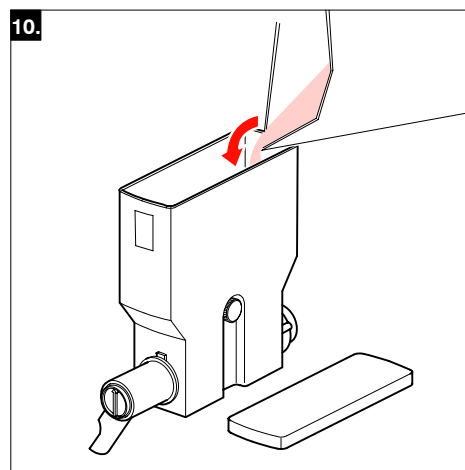
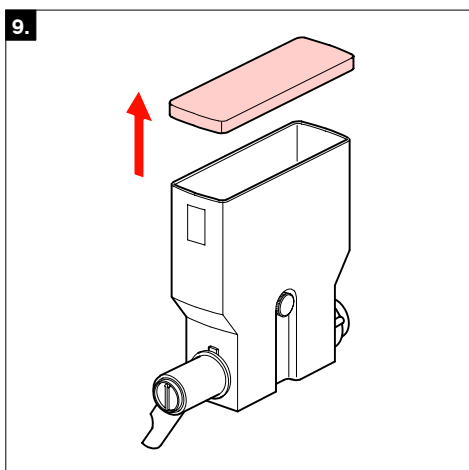
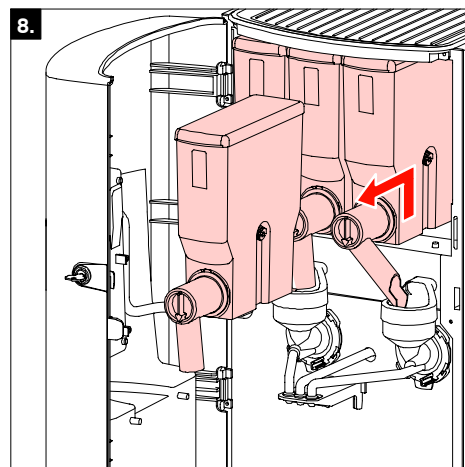
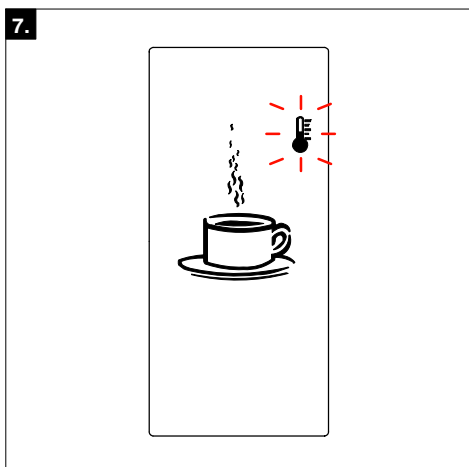
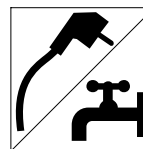

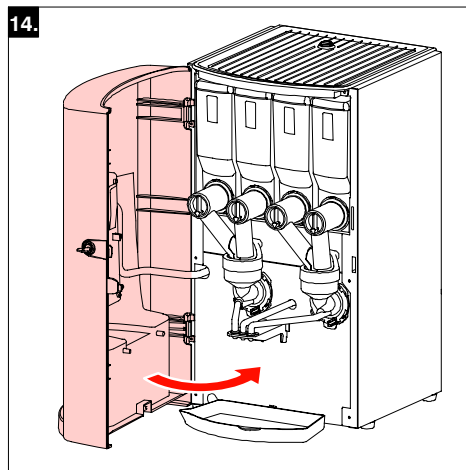
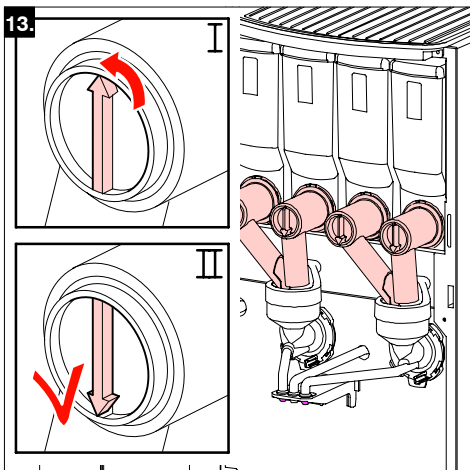

15.

A		B		A		B	
Kaffee	Doppelter Espresso	café long	double espresso	café	café expresso double	café	café expresso double
Kaffee Crème	Wiener Melange	café court	viennese	café crème	café de Vienna	café	café de Vienna
Café Au Lait	Türkischokolade	café au lait	chocolat	café con leche	chocolato	café	chocolato
Cappuccino	Espressohot	cappuccino	caféchoc	cappuccino	espressohot	café	espressohot
Espresso	Hellwasser	espresso	eau chaude	espresso	hot water	café expresso	agua caliente
café	double espresso	café	café expresso double	café	café expresso double	café	café expresso double
café crème	moccachino	café crème	café de Vienna	café	café de Vienna	café	café de Vienna
café au lait	hot chocolate	café con leche	chocolato	café	chocolato	café	chocolato
cappuccino	espressohot	cappuccino	espressohot	café	espressohot	café	espressohot
espresso	hot water	café expresso	agua caliente	café	café expresso	café	café expresso
A		B		A		B	

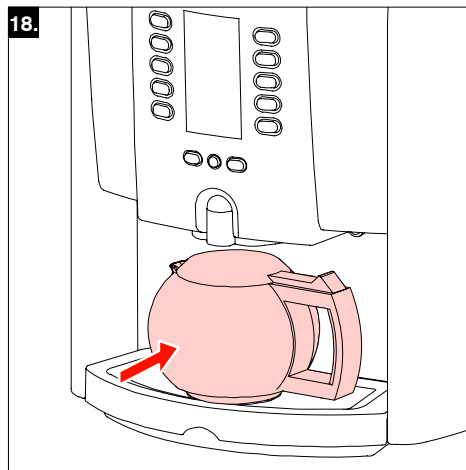
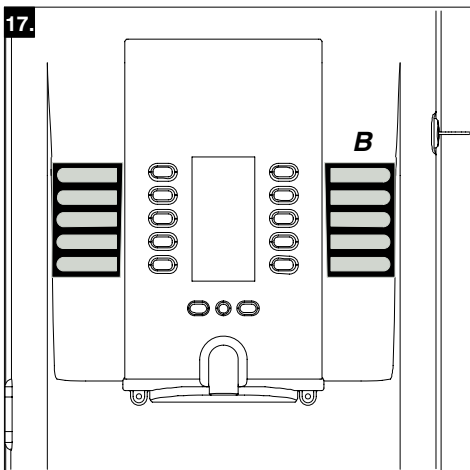
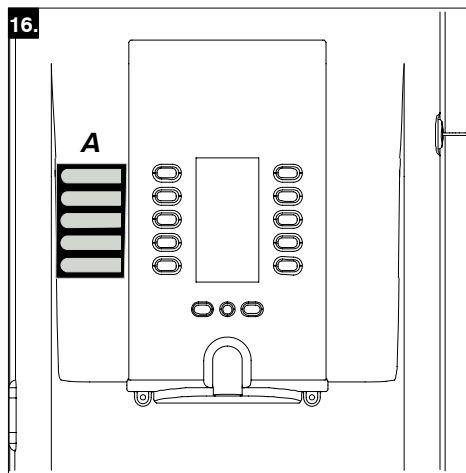

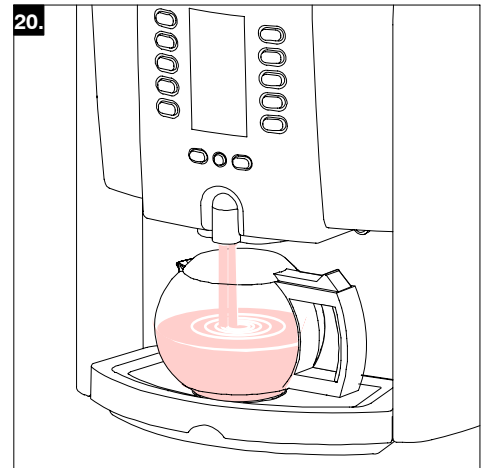
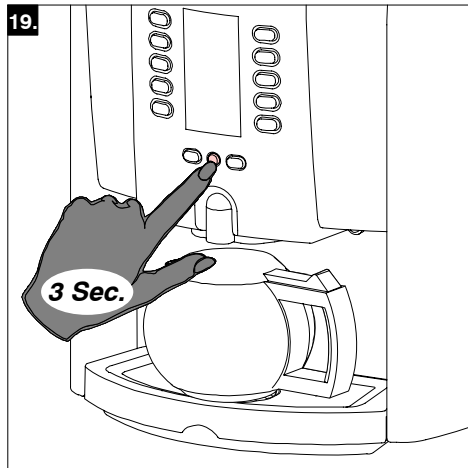



Programming  
Programmation  
Programieren  
Programmeren  
Programmering

Programmering  
Programmering  
Ohjelmointi  
Programar  
Programação

Programmazione  
Προγραμματισμός  
λειτουργίας  
Programování  
Programowanie  
Programare

Программирование  
Programlama  
程式  
プログラミング  
프로그램

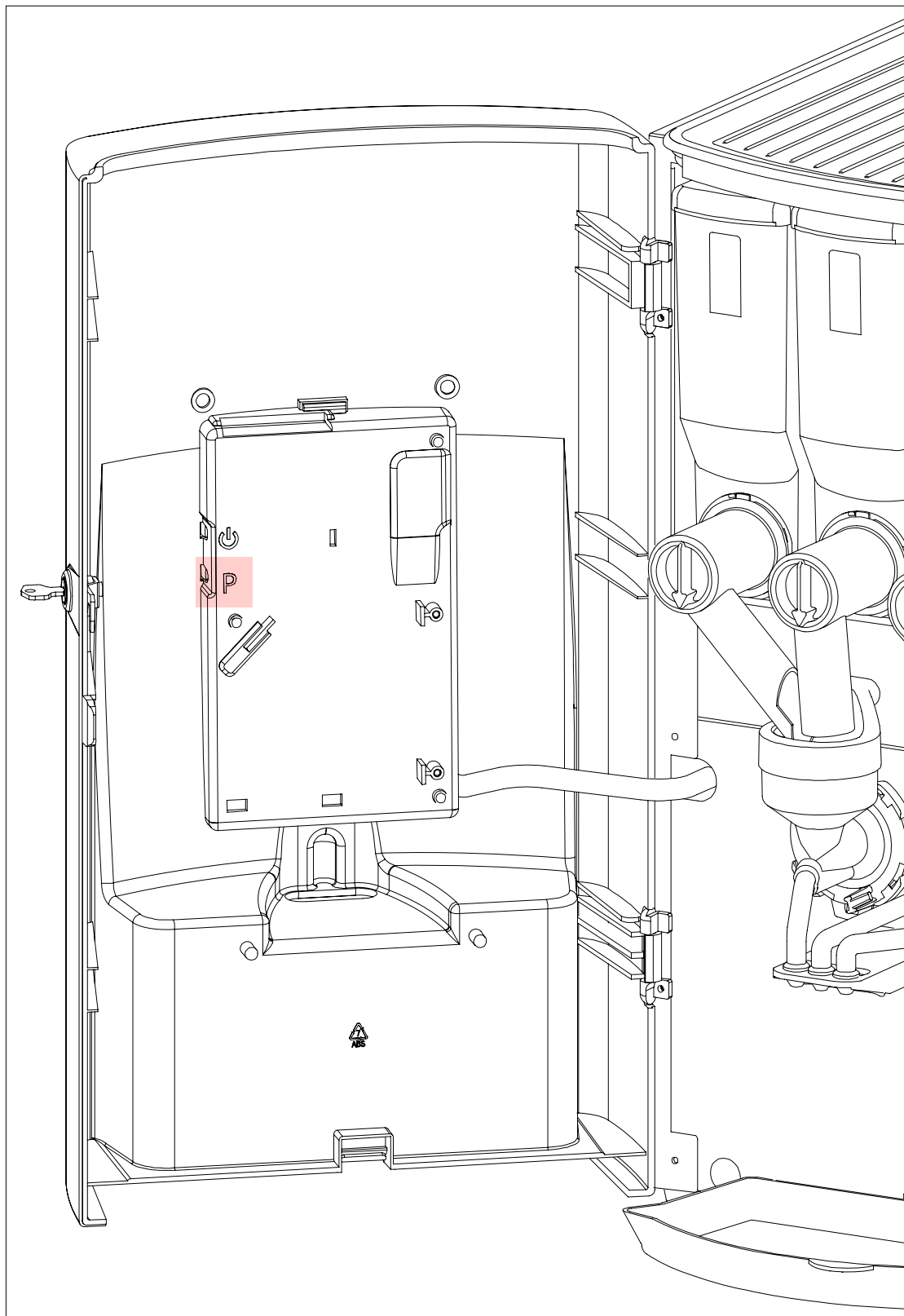

# P

	☒	☐	▲	■	←
English	Off	Minimum value	Standard value	Maximum value	Next step / confirm
Français	Eteint	Valeur minimum	Valeur standard	Valeur maximum	Etape suivante / confirmer
Deutsch	Aus	Minimum Wert	Standard Wert	Maximum Wert	Nächster Schritt / sichern
Nederlands	Uit	Minimum waarde	Standaard waarde	maximum waarde	Volgende stap / bevestigen
Svenska	Av	Minimum värde	Standard värde	Maximalt värde	Nästa steg / Bekräfta
Norsk	Av	Minimum verdi	Standard verdi	Maksimum verdi	Neste steg / Bekreft
Dansk	Slukket	Minimum værdi	Standard værdi	Maksimum værdi	Næste trin / Bekræft
Suomi	Pois päältä	Minimi arvo	Oletusarvo	Maksimi arvo	Seuraava / Vahvista
Español	Apagado	Valor mínimo	Valor estándar	Valor máximo	Próximo nivel / confirmar
Português	Desligado	Valor mínimo	Valor standard	Valor máximo	Próximo passo / confirme
Italiano	Spento	Valore minimo	Valore standart	Valore massimo	Prossimo / passo
Ελληνικά	Εκτός λειτουργίας	Ελάχιστη τιμή	Θυσιολογική τιμή	Μύγιση τιμή	Επόμενο βήμα / επιβεβαίωση
Česky	Vyprnutí	Minimální hodnota	Standardní hodnota	Maximální hodnota	Další krok / potvrdit
Polski	Wyłączony	Minimalna wartość	Standardowa wartość	Maksymalna wartość	Następny krok / potwierdzenie
Română	Oprit	Valoare minimă	Valoare standard	Valoare maximă	Pasul următor / confirma
Русский	Выключено	Минимальный объем	Стандартный объем	Максимальный объем	Следующий шаг / Подтвердить
Türkçe	Kapalı	Minimum değer	Standart değer	Maksimum değer	Sonraki adım / Onayla
中文	關閉	最小價值	標準價值	最大價值	下一步/確認
日本語	オフ	最小値	標準値	最大値	次のステップ
한국	끄 짐	최소치	표준치	최대치	다음단계/확인

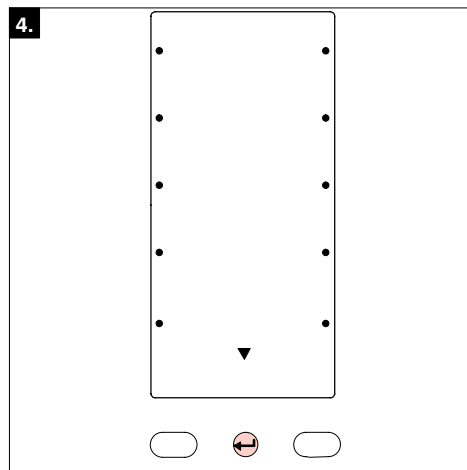
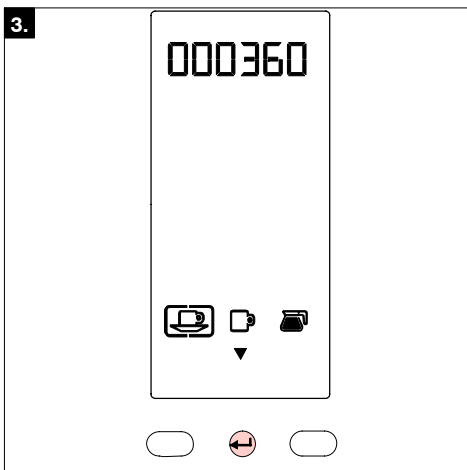
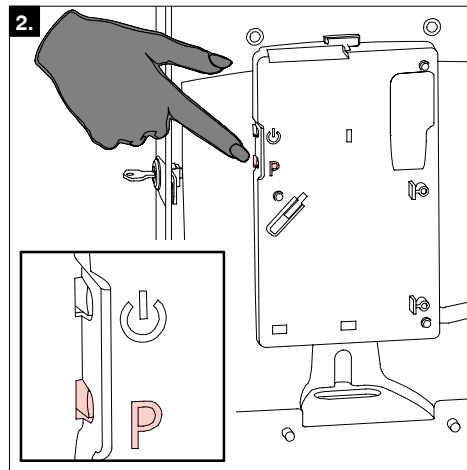
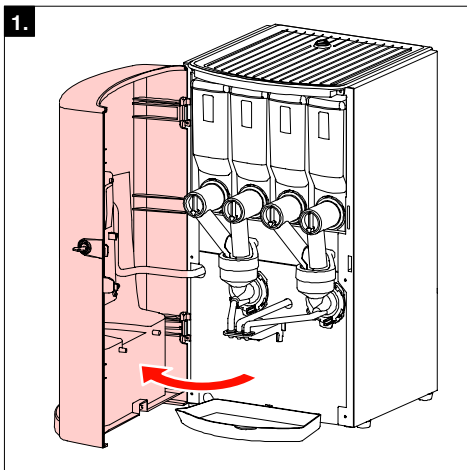

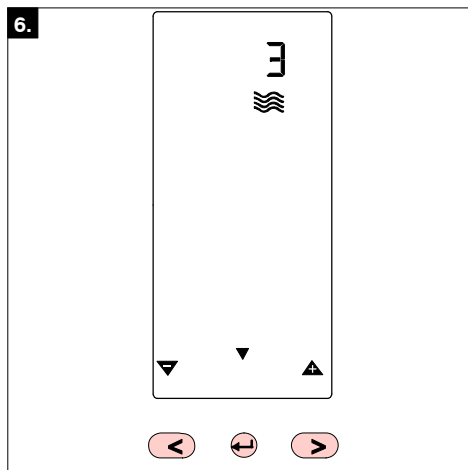
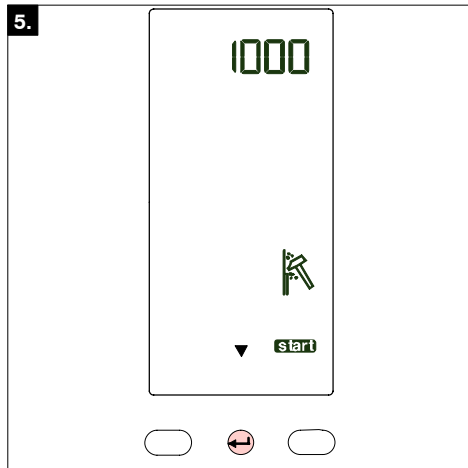

☒  3  
off 1 5

OFF			
1	= 18 - 30 °DH	= 32 - 55 °TH	250 L.
2	= 12 - 18 °DH	= 22 - 32 °TH	500 L.
3	= 08 - 12 °DH	= 15 - 22 °TH	1000 L.
4	= 04 - 08 °DH	= 07 - 15 °TH	1500 L.
5	= 00 - 04 °DH	= 00 - 07 °TH	2000 L.
	4,0 °DH = 0,714 mmol/l		
	10,0 °TH = 1,000 mmol/l		

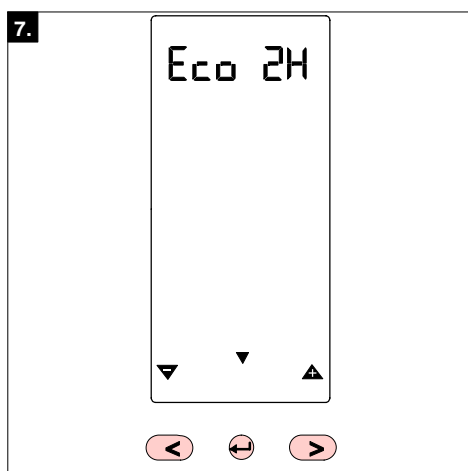

☒  2H  
off 0.15 16H

Descaling signal  
Signalisation d' entartrage  
Entkalkungsanzeige  
Ontkalkingsignalering  
Avkalkningssignal  
Rensesignal  
Afkalknings signal  
Kalkinpoistomerkki  
Señalización de descalcificación  
Sinal de descalcificação  
Identificazione della decalcificazione  
Ένδειξη αφαλάτωσης  
Signal odvápnění  
Sygnał akustyczny odkamieniania  
Semnal decalcarizare  
Сигнал для Ристки от накипи  
Kireçten arındırma sinyali  
除垢訊號

デスケール表示  
스케일 청소 표시

Energy-saving mode  
Mode économique  
Energiesparstufe  
Energie spaarstand  
Energisparläge  
Energisparingsmodus  
Energi spare funktion  
Sähköä säästävää malli  
Posición de economía  
Economizador de energia  
Risparmio energia  
Ένδειξη εξοικονόμησης ενέργειας  
Ochrona energie  
Tryb pracy "eco" oszczędzający energię  
Mod economic  
Экономичный режим  
Enerji tasarrufu modu  
能源節省模式  
省エネモード  
에너지 절약형 모드

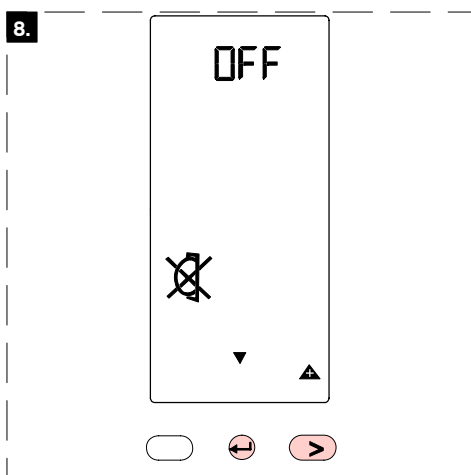

Coin mechanism  
 Monnayeur  
 Münzprüfer  
 Muntmechanisme  
 Myntmekanism  
 Myntmekanisme  
 Møntsystem  
 Kolikkomekanismi  
 Mecanismo de monedas  
 Moedeiro  
 Controllo monete  
 Μηχανισμός κερμάτων  
 Mincovní mechanismus  
 Mechanizm monetowy  
 Mecanism cu fise  
 Монетоприёмник  
 Vozuk para mekanizması  
 硬幣装置



コインメック  
 코인 메커니즘

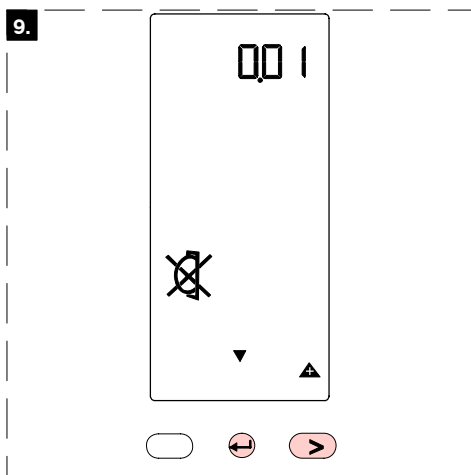

Coins rejection / acceptance (0.01)  
 Refus / acceptation de monnaie (0.01)  
 Münzen abgelehnt/ akzeptiert (0.01)  
 Munt weigering / acceptatie (0.01)  
 Myntretur / accepteras (0.01)  
 Mynt avvisning / aksept (0.01)  
 Mønt retur / accepteret (0.01)  
 Kolikon hylkäys / hyväksyminen (0.01)  
 Negación / aceptación de monedas (0.01)  
 Rejeição de moeda / aceitação (0.01)  
 Accettazione / rifiuto moneta (0.01)  
 Απόρριψη / Απόδοχή κερμάτων (0.01)  
 Možnost připojení / mincovníku (0.01)  
 Odmowa monet / akceptacja monet (0.01)  
 Acceptare / respingere fisă (0.01)  
 Монета непригодна / пригодна (0.01)  
 Vozuk para geri çevirme / kabul (0.01)



硬幣退回/接受 (0.01)  
 コイン却下・受け入れ (0.01)  
 코인 제거/접수 (0.01)

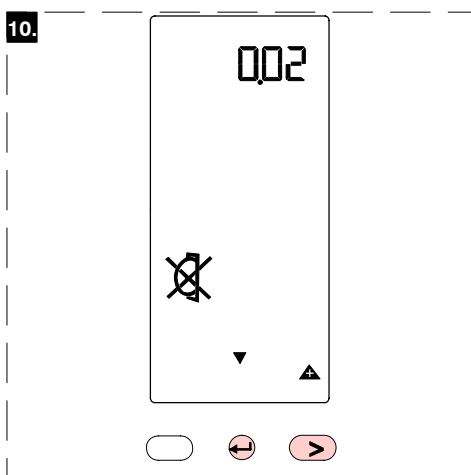

Coins rejection / acceptance (0.02)  
 Refus / acceptation de monnaie (0.02)  
 Münzen abgelehnt/ akzeptiert (0.02)  
 Munt weigering / acceptatie (0.02)  
 Myntretur / accepteras (0.02)  
 Mynt avvisning / aksept (0.02)  
 Mønt retur / accepteret (0.02)  
 Kolikon hylkäys / hyväksyminen (0.02)  
 Negación / aceptación de monedas (0.02)  
 Rejeição de moeda / aceitação (0.02)  
 Accettazione / rifiuto moneta (0.02)  
 Απόρριψη / Απόδοχή κερμάτων (0.02)  
 Možnost připojení / mincovníku (0.02)  
 Odmowa monet / akceptacja monet (0.02)  
 Acceptare / respingere fisă (0.02)  
 Монета непригодна / пригодна (0.02)  
 Vozuk para geri çevirme / kabul (0.02)



硬幣退回/接受 (0.02)  
 コイン却下・受け入れ (0.02)  
 코인 제거/접수 (0.02)

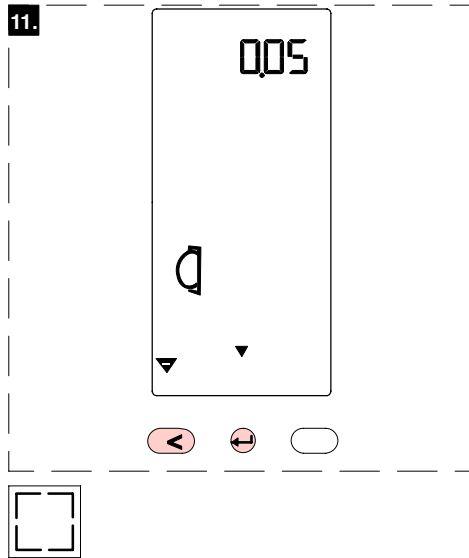

Coins rejection / acceptance (0.05)  
 Refus / acceptation de monnaie (0.05)  
 Münzen abgelehnt/ akzeptiert (0.05)  
 Munt weigering / acceptatie (0.05)  
 Myntretur / accepteras (0.05)  
 Mynt avvisning / aksept (0.05)  
 Mønt retur / accepteret (0.05)  
 Kolikon hylkäys / hyväksyminen (0.05)  
 Rechazación / aceptación de monedas (0.05)  
 Rejeição de moeda / aceitação (0.05)  
 Accettazione / rifiuto moneta (0.05)  
 Απόρριψη / Αποδοχή κερμάτων (0.05)  
 Odmowa monet / akceptacja monet (0.05)  
 Acceptare / respingere fisă (0.05)  
 Монета непригодна / пригодна (0.05)  
 Bozuk para geri çevirme / kabul (0.05)  
 硬幣退回/接受 (0.05)  
 コイン却下・受け入れ (0.05)  
 코인 제거/접수 (0.05)

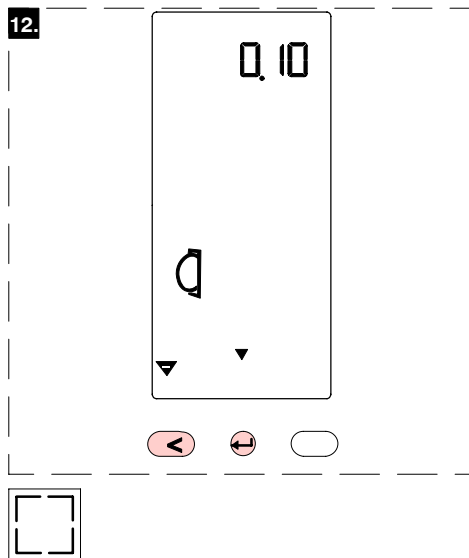

Coins rejection / acceptance (0.10)  
 Refus / acceptation de monnaie (0.10)  
 Münzen abgelehnt/ akzeptiert (0.10)  
 Munt weigering / acceptatie (0.10)  
 Myntretur / accepteras (0.10)  
 Mynt avvisning / aksept (0.10)  
 Mønt retur / accepteret (0.10)  
 Kolikon hylkäys / hyväksyminen (0.10)  
 Rechazación / aceptación de monedas (0.10)  
 Rejeição de moeda / aceitação (0.10)  
 Accettazione / rifiuto moneta (0.10)  
 Απόρριψη / Αποδοχή κερμάτων (0.10)  
 Možnost připojení / mincovníku (0.10)  
 Odmowa monet / akceptacja monet (0.10)  
 Acceptare / respingere fisă (0.10)  
 Монета непригодна / пригодна (0.10)  
 Bozuk para geri çevirme / kabul (0.10)  
 硬幣退回/接受 (0.10)  
 コイン却下・受け入れ (0.10)  
 코인 제거/접수 (0.10)

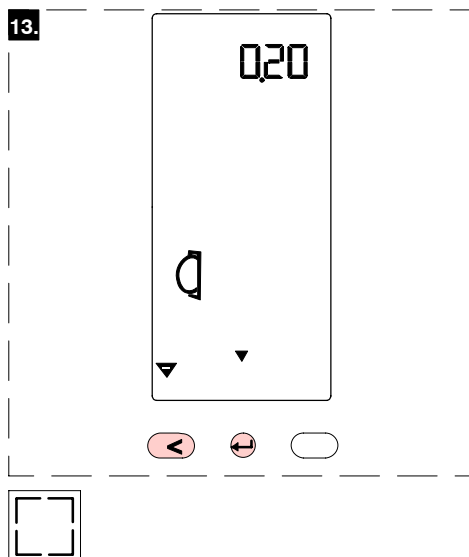

Coins rejection / acceptance (0.20)  
 Refus / acceptation de monnaie (0.20)  
 Münzen abgelehnt/ akzeptiert (0.20)  
 Munt weigering / acceptatie (0.20)  
 Myntretur / accepteras (0.20)  
 Mynt avvisning / aksept (0.20)  
 Mønt retur / accepteret (0.20)  
 Kolikon hylkäys / hyväksyminen (0.20)  
 Rechazación / aceptación de monedas (0.20)  
 Rejeição de moeda / aceitação (0.20)  
 Accettazione / rifiuto moneta (0.20)  
 Απόρριψη / Αποδοχή κερμάτων (0.20)  
 Možnost připojení / mincovníku (0.20)  
 Odmowa monet / akceptacja monet (0.20)  
 Acceptare / respingere fisă (0.20)  
 Монета непригодна / пригодна (0.20)  
 Bozuk para geri çevirme / kabul (0.20)  
 硬幣退回/接受 (0.20)  
 コイン却下・受け入れ (0.20)  
 코인 제거/접수 (0.20)

# P

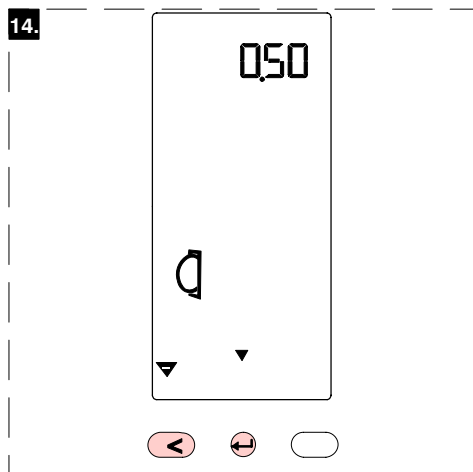

Coins rejection / acceptance (0.50)  
 Refus / acceptation de monnaie (0.50)  
 Münzen abgelehnt/ akzeptiert (0.50)  
 Munt weigering / acceptatie (0.50)  
 Myntretur / accepteras (0.50)  
 Mynt avvisning / aksept (0.50)  
 Mønt retur / accepteret (0.50)  
 Kolikon hylkäys / hyväksyminen (0.50)  
 Rechazación / aceptación de monedas (0.50)  
 Rejeição de moeda / aceitação (0.50)  
 Accettazione / rifiuto moneta (0.50)  
 Απόρριψη / Αποδοχή κερμάτων (0.50)  
 Možnost připojení / mincovníku (0.50)  
 Odmowa monet / akceptacja monet (0.50)  
 Acceptare / respingere fisă (0.50)  
 Монета непригодна / пригодна (0.50)  
 Bozuk para geri çevirme / kabul (0.50)  
 硬幣退回/接受 (0.50)  
 コイン却下・受け入れ (0.50)  
 코인 제거/접수 (0.50)

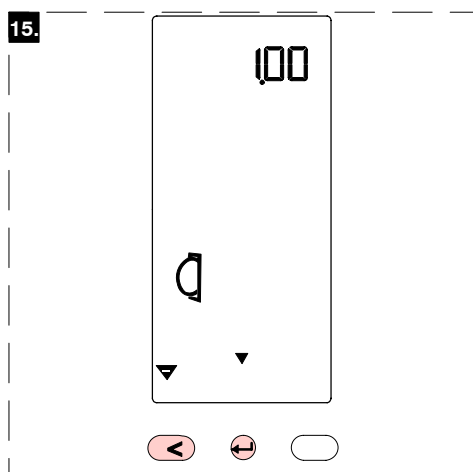

Coins rejection / acceptance (1.00)  
 Refus / acceptation de monnaie (1.00)  
 Münzen abgelehnt/ akzeptiert (1.00)  
 Munt weigering / acceptatie (1.00)  
 Myntretur / accepteras (1.00)  
 Mynt avvisning / aksept (1.00)  
 Mønt retur / accepteret (1.00)  
 Kolikon hylkäys / hyväksyminen (1.00)  
 Rechazación / aceptación de monedas (1.00)  
 Rejeição de moeda / aceitação (1.00)  
 Accettazione / rifiuto moneta (1.00)  
 Απόρριψη / Αποδοχή κερμάτων (1.00)  
 Možnost připojení / mincovníku (1.00)  
 Odmowa monet / akceptacja monet (1.00)  
 Acceptare / respingere fisă (1.00)  
 Монета непригодна / пригодна (1.00)  
 Bozuk para geri çevirme / kabul (1.00)  
 硬幣退回/接受 (1.00)  
 コイン却下・受け入れ (1.00)  
 코인 제거/접수 (1.00)

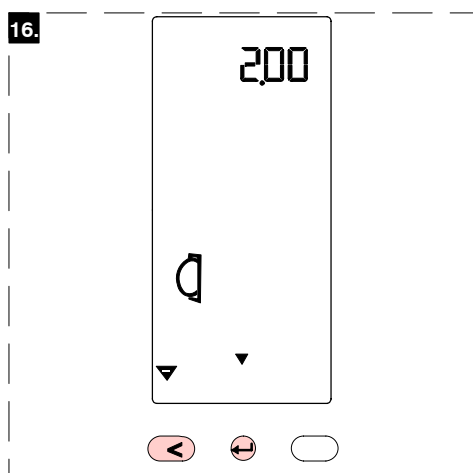

Coins rejection / acceptance (2.00)  
 Refus / acceptation de monnaie (2.00)  
 Münzen abgelehnt/ akzeptiert (2.00)  
 Munt weigering / acceptatie (2.00)  
 Myntretur / accepteras (2.00)  
 Mynt avvisning / aksept (2.00)  
 Mønt retur / accepteret (2.00)  
 Kolikon hylkäys / hyväksyminen (2.00)  
 Rechazación / aceptación de monedas (2.00)  
 Rejeição de moeda / aceitação (2.00)  
 Accettazione / rifiuto moneta (2.00)  
 Απόρριψη / Αποδοχή κερμάτων (2.00)  
 Možnost připojení / mincovníku (2.00)  
 Odmowa monet / akceptacja monet (2.00)  
 Acceptare / respingere fisă (2.00)  
 Монета непригодна / пригодна (2.00)  
 Bozuk para geri çevirme / kabul (2.00)  
 硬幣退回/接受 (2.00)  
 コイン却下・受け入れ (2.00)  
 코인 제거/접수 (2.00)

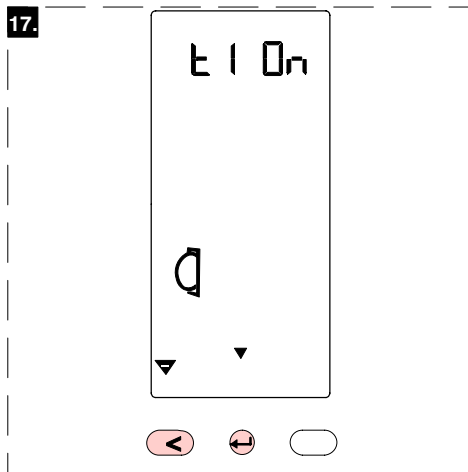

1 = "Freedom Eagle"

Token 1 rejection / acceptance  
 Refus / acceptation de jeton 1  
 Automatenmünze 1 abgelehnt/ akzeptiert  
 Penning 1 weigering / acceptatie  
 Pollett 1 retur / accepteras  
 Pollett 1 avvisning / aksept  
 Møntindkast 1 retur / accepteret  
 Poletti 1 hylkäys / hyväksyminen  
 Rechazación / aceptación de ficha 1  
 Rejeição de moeda 1/ aceitação  
 Accettazione / rifiuto gettone 1  
 Απόρριψη / Αποδοχή Μαρχα 1  
 Žeton 1 prírojení / mincovníku  
 Žeton 1 odmowa / akceptacja  
 Acceptare / respingere jeton1  
 Жетон 1 непригодна / пригодна  
 Jeton 1 çevirme / kabul  
 代用幣 回/接受 1  
 コイン使用 不可/可 1  
 토큰 1

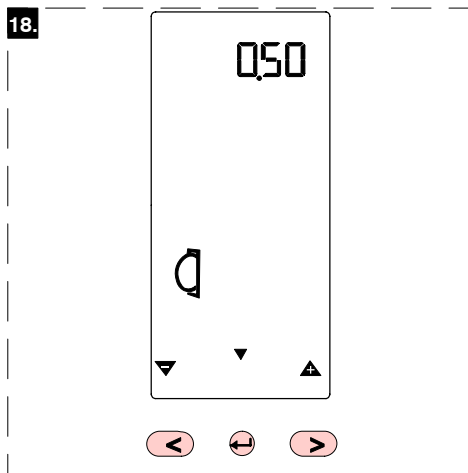

Value token 1  
 Valeur de jeton 1  
 Wert Automatenmünze 1  
 Waarde penning 1  
 Pollett 1 valör  
 Verdi pollett 1  
 Møntindkast 1 værdi  
 Arvopoletti 1  
 Valor de ficha 1  
 Valor moeda 1  
 Valore del gettone 1  
 Αξια Μαρχας 1  
 Hodnota žeton 1  
 Cena žeton 1  
 Valoare jeton 1  
 Номинал жетон 1  
 Jeton 1 degeri  
 代用幣價值 1  
 投入金額 1  
 토큰금액 1

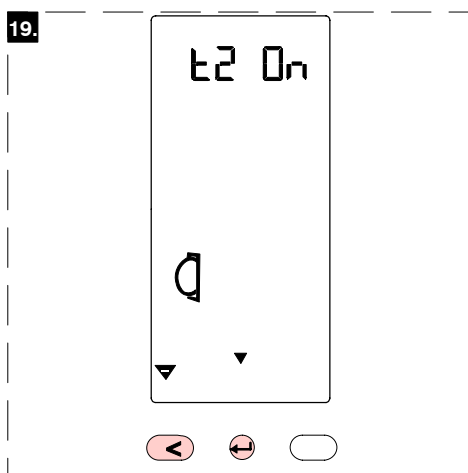

Token 2 rejection / acceptance  
 Refus / acceptation de jeton 2  
 Automatenmünze 2 abgelehnt/ akzeptiert  
 Penning 2 weigering / acceptatie  
 Pollett 2 retur / accepteras  
 Pollett 2 avvisning / aksept  
 Møntindkast 2 retur / accepteret  
 Poletti 2 hylkäys / hyväksyminen  
 Rechazación / aceptación de ficha 2  
 Rejeição de moeda 2/ aceitação  
 Accettazione / rifiuto gettone 2  
 Απόρριψη / Αποδοχή Μαρχα 2  
 Žeton 2 prírojení / mincovníku  
 Žeton 2 odmowa / akceptacja  
 Acceptare / respingere jeton 2  
 Жетон 2 непригодна / пригодна  
 Jeton 2 çevirme / kabul  
 代用幣 回/接受 2  
 コイン使用 不可/可 2  
 토큰 2

# P

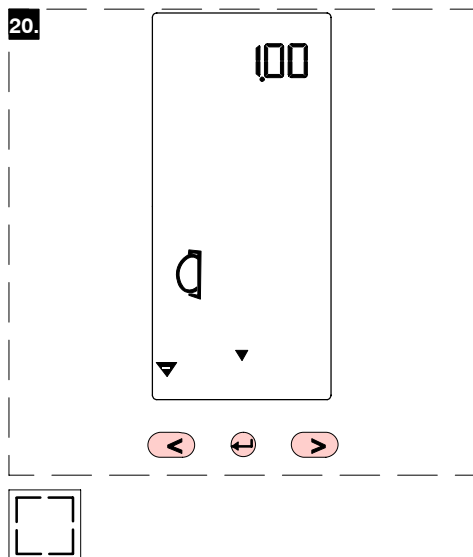

Value token 2  
Valeur de jeton 2  
Wert Automatenmünze 2  
Waarde penning 2  
Pollett 2 valör  
Verdi pollett 2  
Møntindkast 2 værdi  
Arvopoletti 2  
Valor de ficha 2  
Valor moeda 2  
Valore del gettone 2  
Αξια Μαρχας 2  
Hodnota žeton 2  
Cena žeton 2  
Valoare jeton 2  
Номинал жетону 2  
Jeton 2 degeri  
代用幣價值 2  
投入金額 2  
토큰금액 2

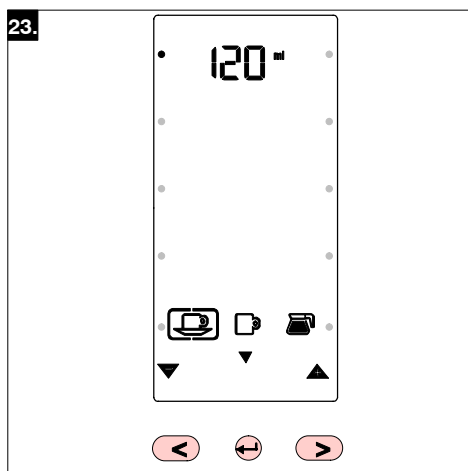
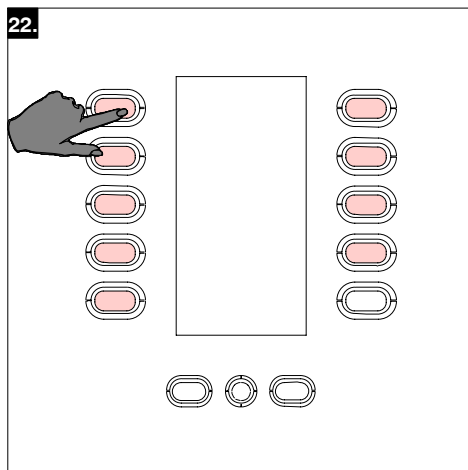
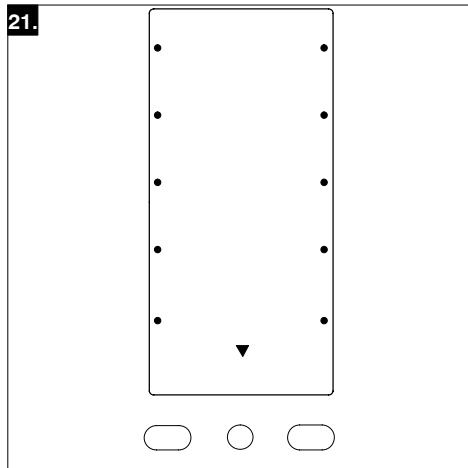

☒ ☐ ————— ■  
off 20 720

Programming (drink dependent)  
 Programmation (selon boisson)  
 Programmieren (Getränke abhängig)  
 Programmeren (drank afhankelijk)  
 Programmering (färdig dryck)  
 Programmering (drikkeavhengig)  
 Programmering (afhængig af drik)  
 Ohjelmointi (juomakohtainen)  
 Programar (dependiendo a la bebida)  
 Programação (bebida dependente)  
 Programmazione (dipendendo bevando)  
 Προγραμματισμός λειτουργίας (αναλόγως ποτού)  
 Programování (závisí na nápoji)  
 Programowanie (w zależności od rodzaju napoju)  
 Programar (dependență de băutura)  
 Программирование (выбранного напитка)  
 Programlama (İçeceğe bağlı)  
 程式 (按飲品)  
 プログラミング (種類別に設定)  
 프로그램 (음료의 종류에 따라 다름)

Amount per cup (drink dependent)  
 Quantité par tasse (selon boisson)  
 Füllmenge Tasse (Getränke abhängig)  
 Doseergrootte kop (drank afhankelijk)  
 Kvantitet/kopp (färdig dryck)  
 Mengde pr. kopp (drikkeavhengig)  
 Mængde pr. kop (afhængig af drik)  
 Määrä / kuppi (juomakohtainen)  
 Dos. grandeza de taza (dependiendo a la bebida)  
 Quantidade por chávena (bebida dependente)  
 Dosaggio per tazza (dipendendo bevando)  
 Ποσότητα ανά φλιτζάνι (αναλόγως ποτού)  
 Množství na šálek (závisí na nápoji)  
 Ilość na filiżankę (w zależności od rodzaju napoju)  
 Cantitate per ceașcă (dependență de băutura)  
 Доза выбранного напитка на Рашку  
 Bir fincan için miktarı (İçeceğe bağlı)  
 每小杯份量 (按飲品)  
 小カップ一杯当りの量 (種類別に設定)  
 컵당 량 (음료의 종류에 따라 다름)

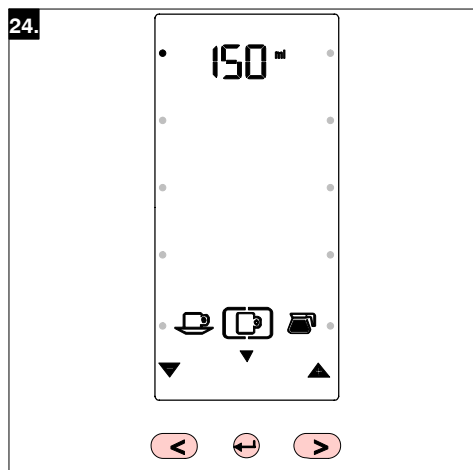

☒ ☐  off 20  720

Amount per mug (drink dependent)  
 Quantité par grande tasse (selon boisson)  
 Füllmenge Becher (Getränk abhängig)  
 Doseergrootte beker (drank afhankelijk)  
 Kvantitet/mugg (färdig dryck)  
 Mengde pr. krus (drikkeavhengig)  
 Mængde pr. krus (afhængig af drik)  
 Määrä / muki (juomakohtainen)  
 Dos. grandeza de tazón (dependiendo a la bebida)  
 Quantidade por caneca (bebida dependente)  
 Dosaggio tazza grande (dipendendo bevando)  
 Ποσότητα ανά κούπα (αναλόγως ποτού)  
 Množství na džbánek (závisí na nápoji)  
 Ilość na kubek (w zależności od rodzaju napoju)  
 Cantitate per cană (dependentă de băutură)  
 Доза выбранного напитка на кружку  
 Bir maşrapa için miktarı (İçeceği bağlı)  
 每大杯份量(按飲品)

大カップ一杯当りの量 (種類別に設定)  
 머그컵당 량(음료의 종류에 따라 다름)

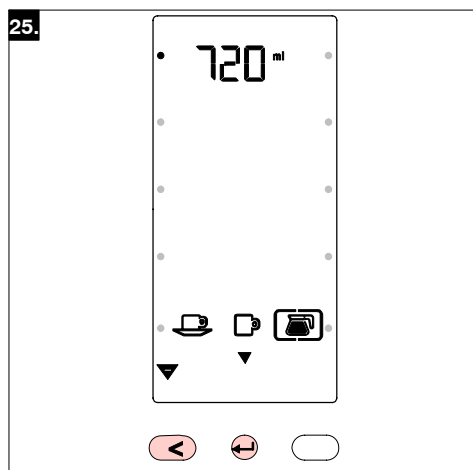

☒ ☐  off 20  720

Amount per decanter (drink dependent)  
 Quantité par pichet (selon boisson)  
 Füllmenge Kanne (Getränk abhängig)  
 Doseergrootte kan (drank afhankelijk)  
 Kvantitet/kanna (färdig dryck)  
 Mengde pr. kanne (drikkeavhengig)  
 Mængde pr. kande (afhængig af drik)  
 Määrä / kannu (juomakohtainen)  
 Dos. grandeza de jarra (dependiendo a la bebida)  
 Quantidade por jarro (bebida dependente)  
 Dosaggio per Bricco (dipendendo bevando)  
 Ποσότητα ανά κανάτα (αναλόγως ποτού)  
 Množství na konvici (závisí na nápoji)  
 Ilość na dzbanek (w zależności od rodzaju napoju)  
 Cantitate per bol (dependentă de băutură)  
 Доза выбранного напитка на графин  
 Bir pot için miktarı (İçeceği bağlı)  
 每壺份量(按飲品)

デカンター一杯当りの量 (種類別に設定)  
 디켄터당 량(음료의 종류에 따라 다름)

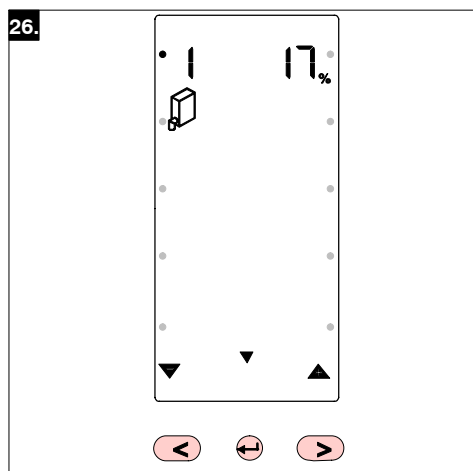

☐  0  100

Basic strength (drink dependent)  
 Réglage goût de base (selon boisson)  
 Basis Stärke (Getränk abhängig)  
 Basis sterkte (drank afhankelijk)  
 Normal styrka (färdig dryck)  
 Grunnstyrke (drikkeavhengig)  
 Standard styrke (afhængig af drik)  
 Normaali vahvuus (juomakohtainen)  
 Fuerza básica (dependiendo a la bebida)  
 Dureza básica (bebida dependente)  
 Gusto standart (dipendendo bevando)  
 Βασική ισχύς (αναλόγως ποτού)  
 Základní množství (závisí na nápoji)  
 Podstawowa moc (w zależności od rodzaju napoju)  
 Concentrație de bază (dependentă de băutură)  
 Базовая насыщенность выбранного напитка  
 Normal kuvvette (İçeceği bağlı)  
 基本濃度(按飲品)

標準濃度 (種類別に設定)  
 기본농도(음료의 종류에 따라 다름)

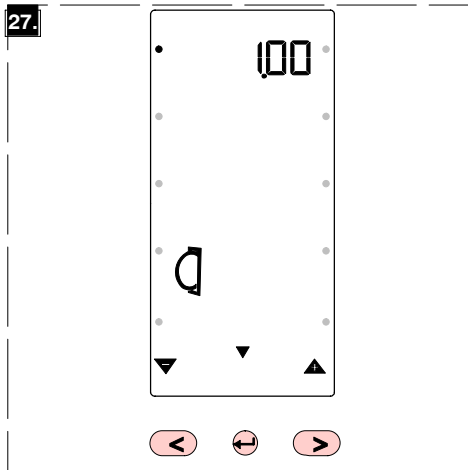

Price-fixing (drink dependent)  
 Indice prix (selon boisson)  
 Preis (Getränke abhängig)  
 Prijsstelling (drank afhankelijk)  
 Bestäm pris (färdig dryck)  
 Satt pris (drikkeavhengig)  
 Pris indstilling (afhængig af drik)  
 Hinnan sääätö (juomakohtainen)  
 Regulación de precios (dependiendo a la bebida)  
 Atribuir preço (bebida dependente)  
 Prezzo (dipendendo bevando)  
 Ρυθμιστής τιμής (αναλόγως ποτού)  
 Programování ceny (závisí na nápoji)  
 Ustawianie ceny (w zależności od rodzaju napoju)  
 Cotă stabilită in pret (dependent de băutura)  
 Цена выбранного напитка  
 Ücret sabitleme (İçeceği bağı)  
 定價 (按飲品)  
 価格設定 (種類別に設定)  
 고정가격(음료의 종류에 따라 다름)

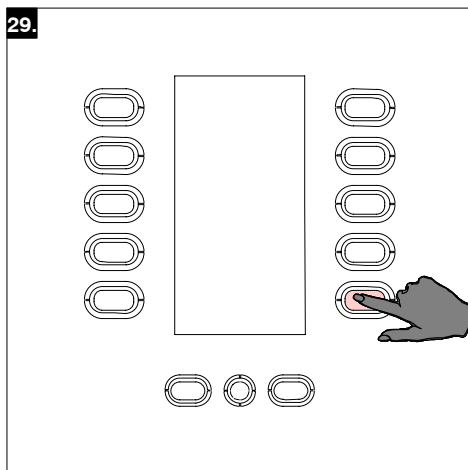
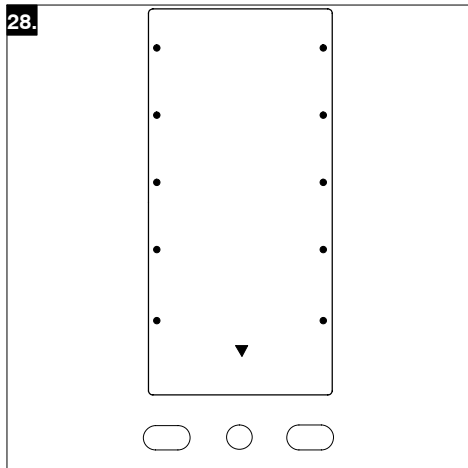

Programming (hot water)  
 Programmation (d'eau chaude)  
 Programmieren (Heißwasser)  
 Programmeren (hot water)  
 Programmering (hetvatten)  
 Programmering (varmt vann)  
 Programmering (varmt vand)  
 Ohjelmointi (kuuma vesi)  
 Programar (água caliente)  
 Programação (água quente)  
 Programmazione (acqua calda)  
 Προγραμματισμός λειτουργίας (καυτού νερού)  
 Programování (horké vody)  
 Programowanie (wody gorącej)  
 Programar (fierbinte)  
 Программирование (горячей воды)  
 Programlama (sıcak su)  
 程式 (熱水)  
 プログラミング (熱湯)  
 프로그램 (더운물)

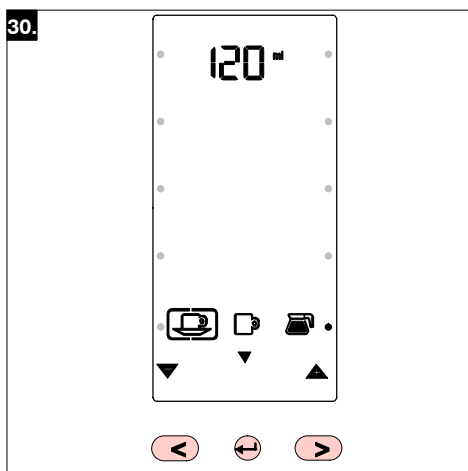

Amount of hot water per cup  
 Quantité d'eau chaude par tasse  
 Füllmenge Tasse Heißwasser  
 Doseergrootte kop heet water  
 Kvantitet hetvatten/kopp  
 Mengde varmt vann pr. kopp  
 Mængde af varmt vand pr. kop  
 Kuuman veden määrä / kuppi  
 Dosificación grandeza de taza de agua caliente  
 Quantidade de água quente por chávena  
 Quantità acqua calda per tazza  
 Ποσότητα καυτού νερού ανά φλιτζάνι  
 Množství horké vody na šálek  
 Ilość wody gorącej na filiżankę  
 Cantitatea apă fierbinte per ceașcă  
 Количество горячей воды на Рашку  
 Bir fincan için sıcak su miktarı  
 每小杯熱水份量  
 小カップ一杯当りの熱湯の量  
 컵당 더운물의 량

—————   
 off 20 720

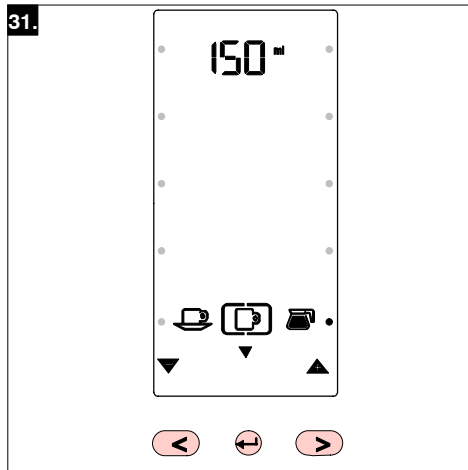

☒ ☐ ————— ■  
off 20 720

Amount of hot water per mug  
Quantité d'eau chaude par grande tasse  
Füllmenge Becher Heißwasser  
Doseergrootte beker heet water  
Kvantitet hetvatten/mugg  
Mengde varmt vann pr. krus  
Mængde af varmt vand pr. krus  
Kuuman veden määrä / muki  
Dosificación grandeza de tazón de agua caliente  
Quantidade de água quente por caneca  
Quantità acqua calda per tazza grande  
Ποσότητα καυτού νερού ανά κούπα  
Množství horké vody na džbánek  
Ilość wody gorącej na kubek  
Cantitatea apă fierbinte per cană  
Количество горячей воды на кружку  
Bir maşğara için sıcak su miktarı  
每大杯熱水份量

大カップ一杯当りの熱湯の量  
머그컵당 더운물의 량

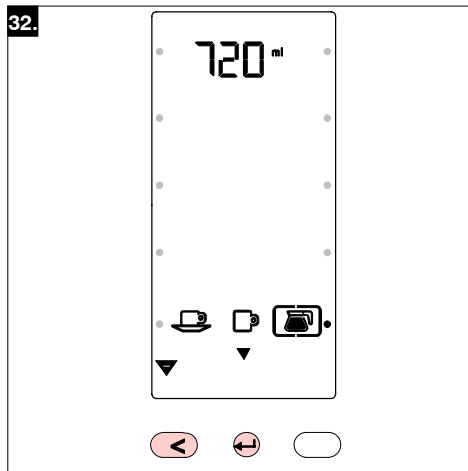

☒ ☐ ————— ■  
off 20 720

Amount of hot water per decanter  
Quantité d'eau chaude par pichet  
Füllmenge Kanne Heißwasser  
Doseergrootte kan heet water  
Kvantitet hetvatten/kanna  
Mengde varmt vann pr. kanne  
Mængde af varmt vand pr. kande  
Kuuman veden määrä / kannu  
Dosificación grandeza de jarra de agua caliente  
Quantidade de água quente por jarro  
Quantità acqua calda per bricco  
Ποσότητα καυτού νερού ανά κανάτα  
Množství horké vody na konvici  
Ilość wody gorącej na dzbanek  
Cantitatea de apă fierbinte per bol  
Количество горячей воды на графин  
Bir pot için sıcak su miktarı  
每壺熱水份量

デカンター一杯当りの熱湯の量  
디켄터당 더운물의 량

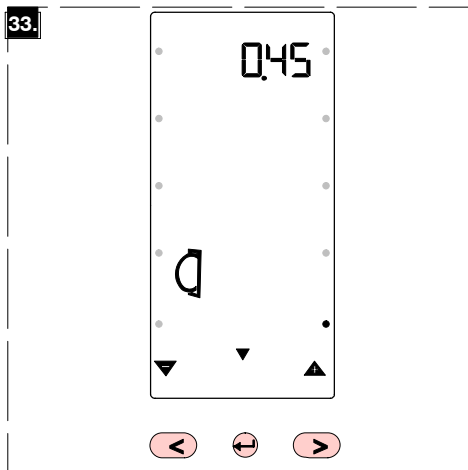

Price-fixing hot water  
Indice prix eau chaude  
Preis Heißwasser  
Prijstelling heet water  
Bestäm pris på vatten  
Satt pris varmt vann  
Pris indstilling varmt vand  
Hinnan säätö kuuma vesi  
Regulación de agua caliente  
Atribuir preço água quente  
Prezzo acqua calda  
Ρυθμιστής τιμής καυτού νερού  
Programování ceny horké vody (čaje)  
Ustawianie ceny (wrzatkę)  
Cotă apă fierbinte stabilită in preț  
Цена воды  
Sıcak su ücret sabitleme  
熱水定價

価格設定された熱湯  
고정가격( 더운물)

# P

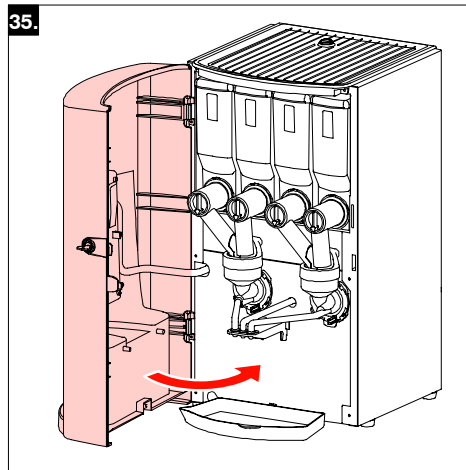
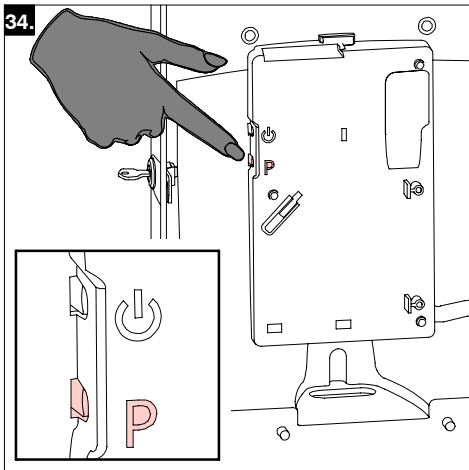

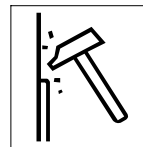

**Descaling**  
**Détartrage**  
**Entkalkung**  
**Ontkalken**  
**Avkalkning**

**Rensing**  
**Afkalkning**  
**Kalkinpoisto**  
**Descalcificaci3n**  
**Descalcificac3o**

**Decalcificazione**  
**Αφαλάτωση**  
**Odv3pn3ní**  
**Odkamienianie**  
**Decalcarizare**

**уИСТКА ОТ НАКИПИ**  
**Kireçten arındırma**  
**除垢**  
**デスケール**  
**스케일 청소**

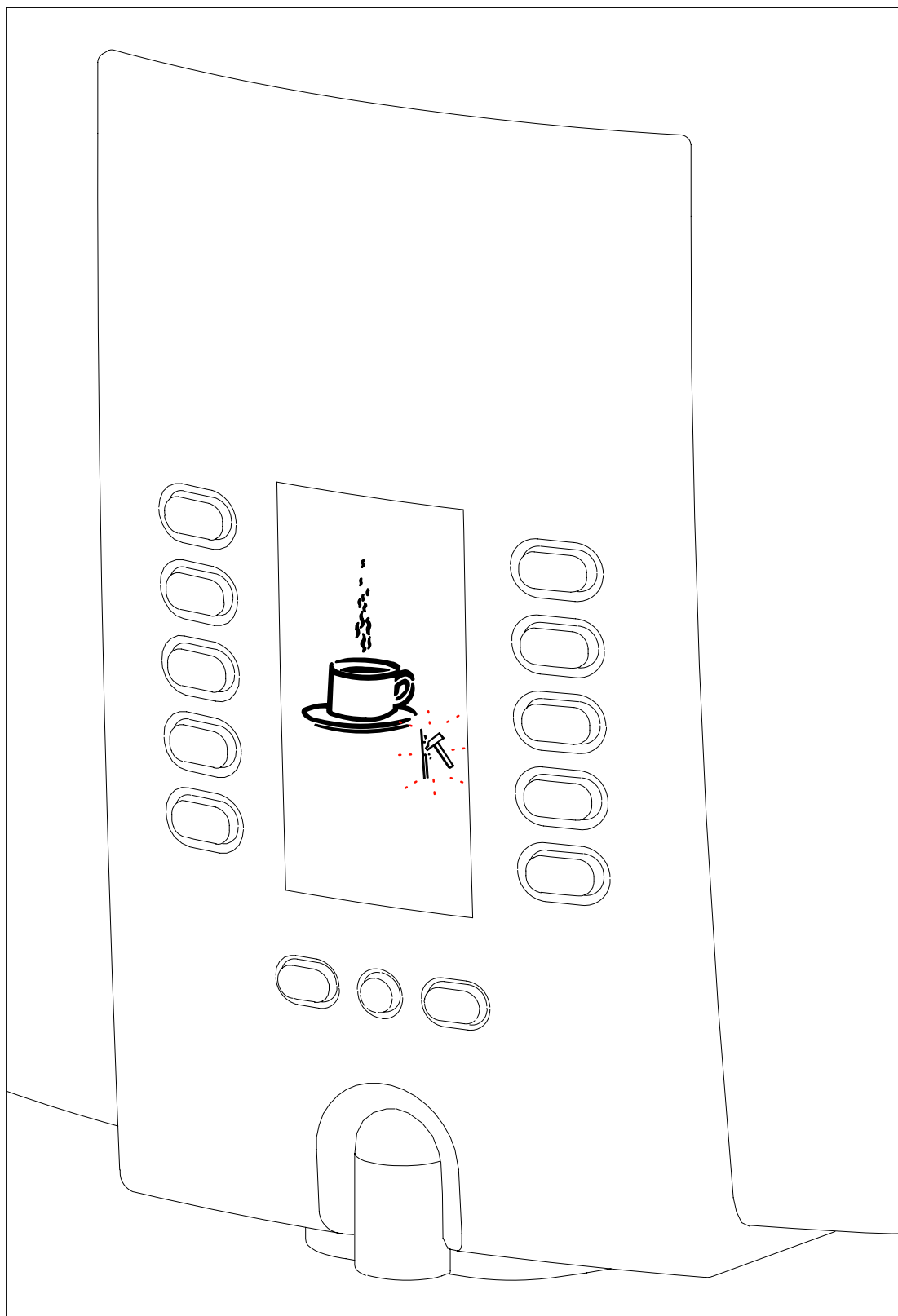

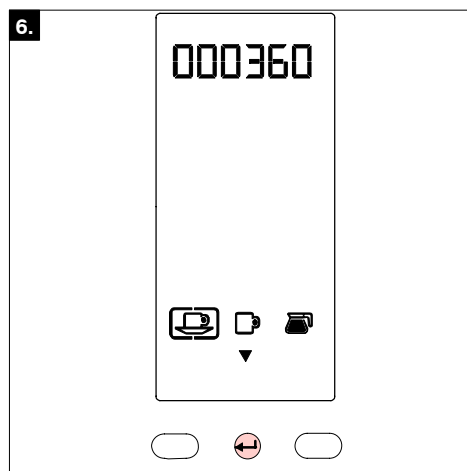
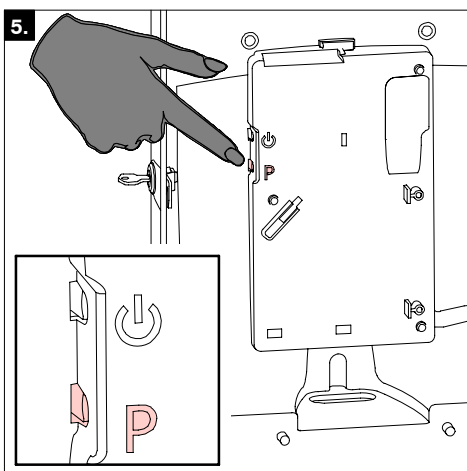
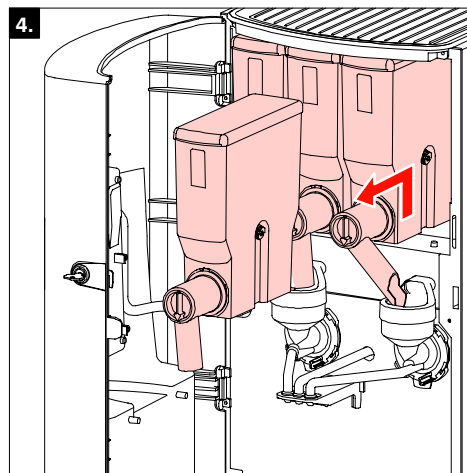
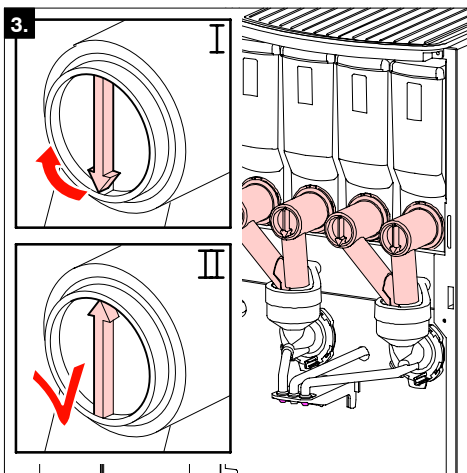
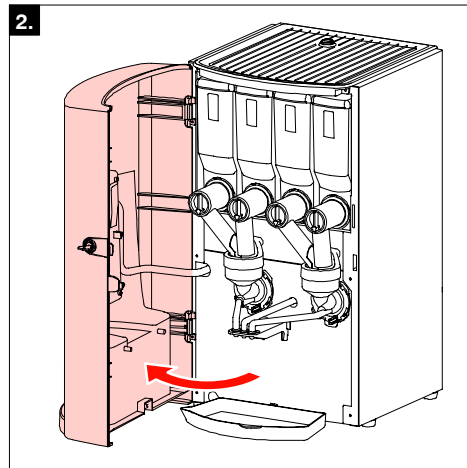
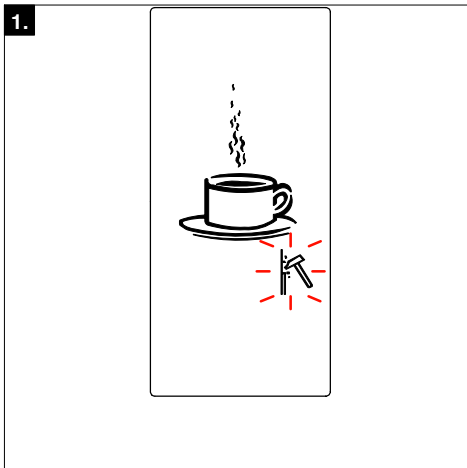
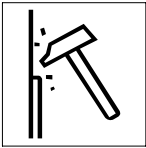

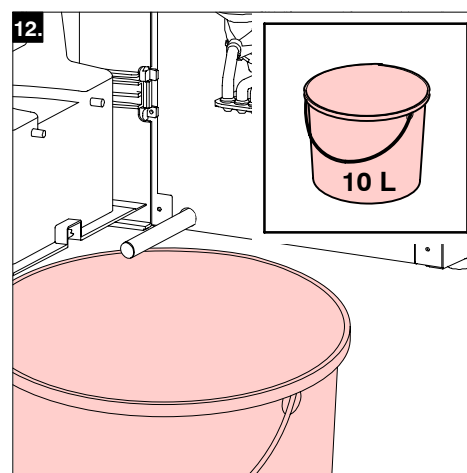
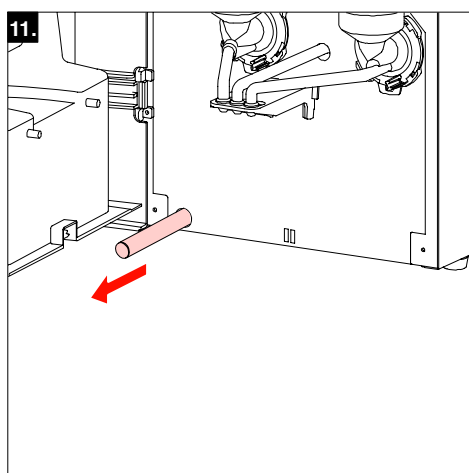
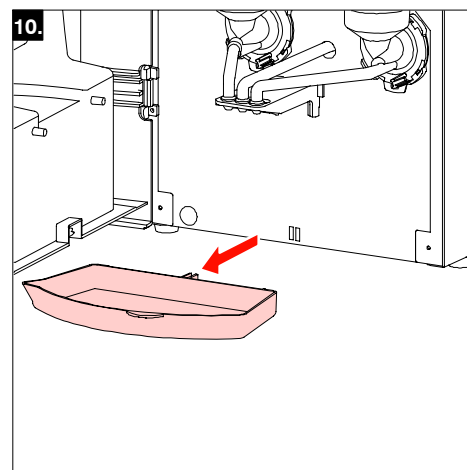
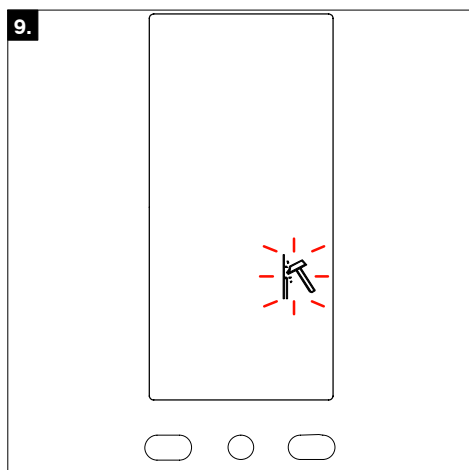
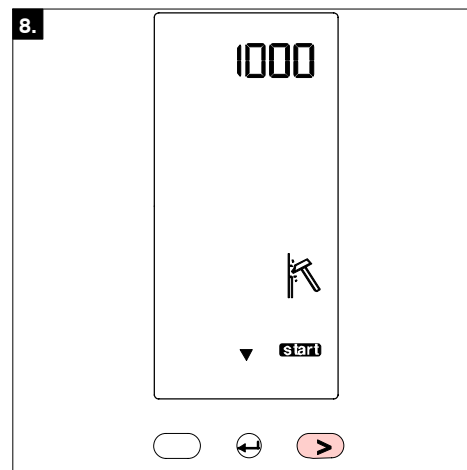
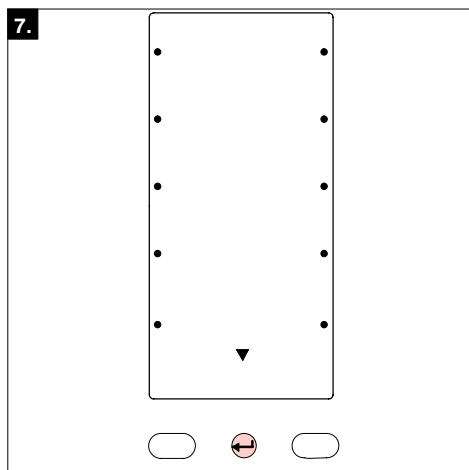
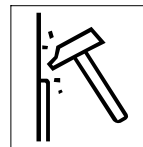

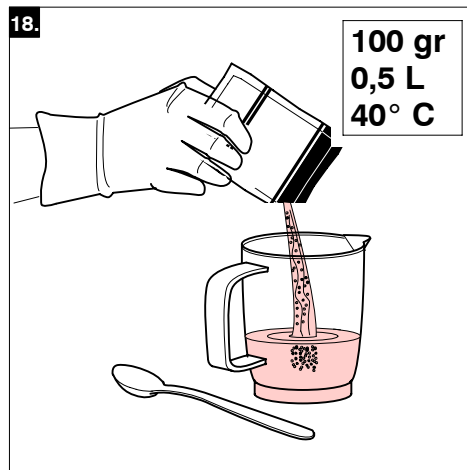
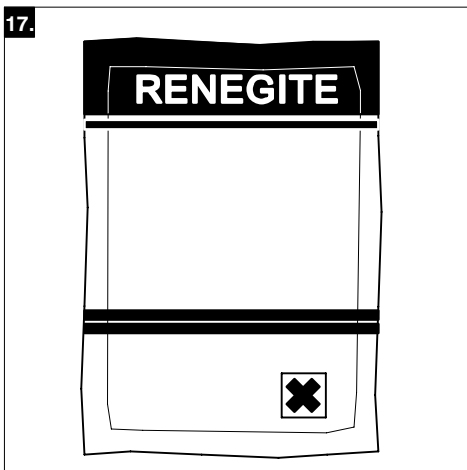
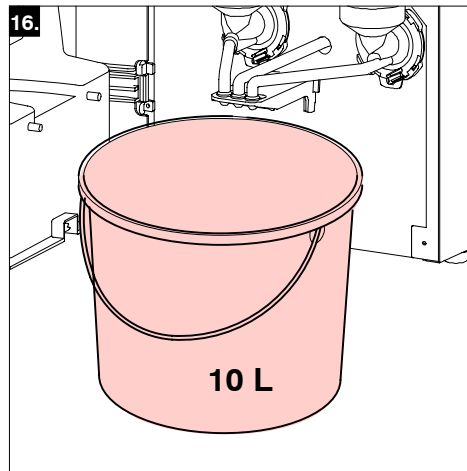
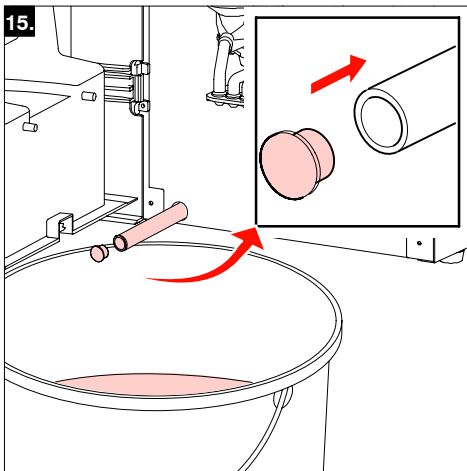
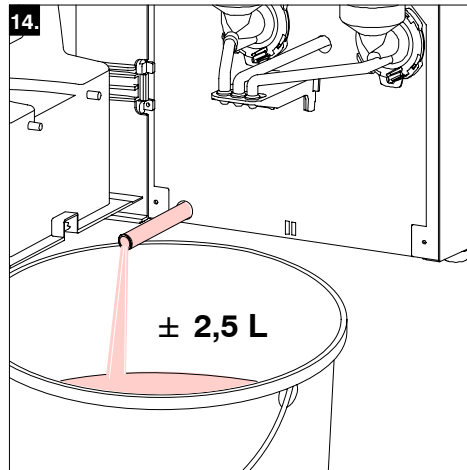
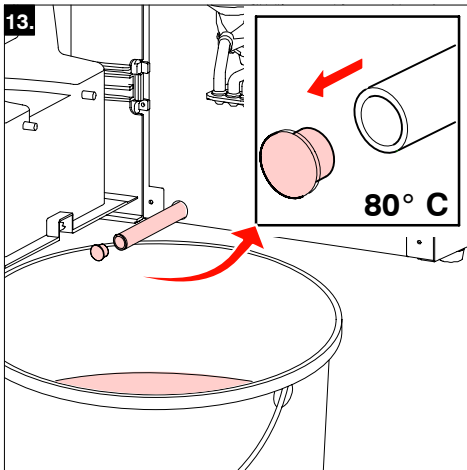

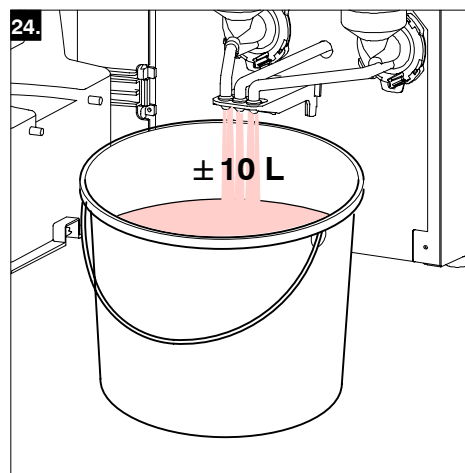
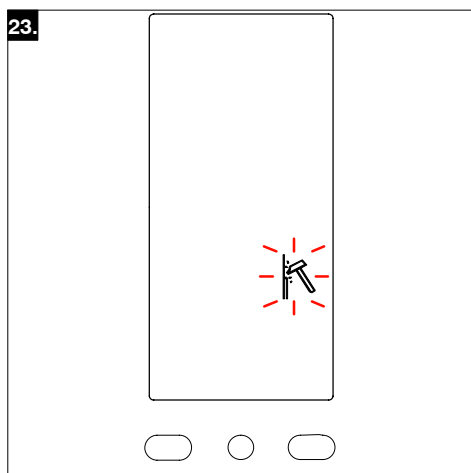
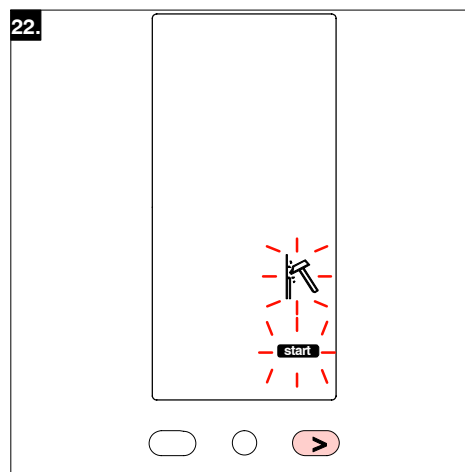
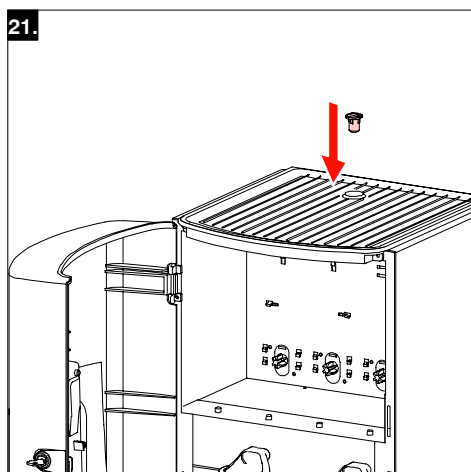
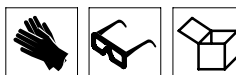
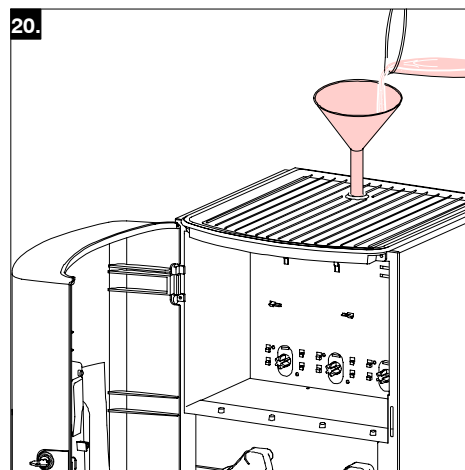
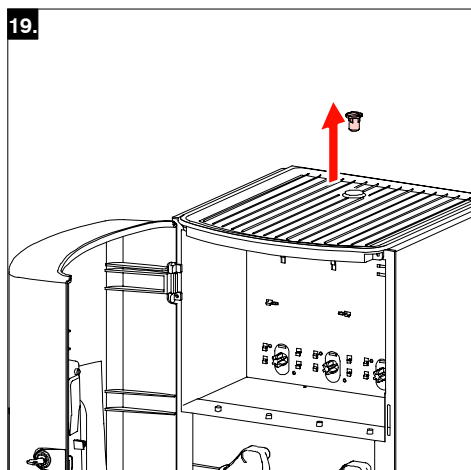
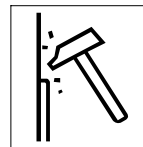

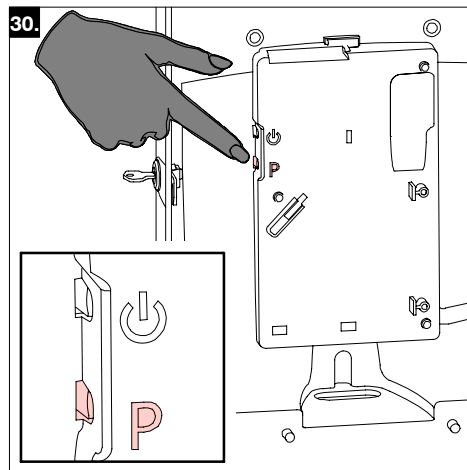
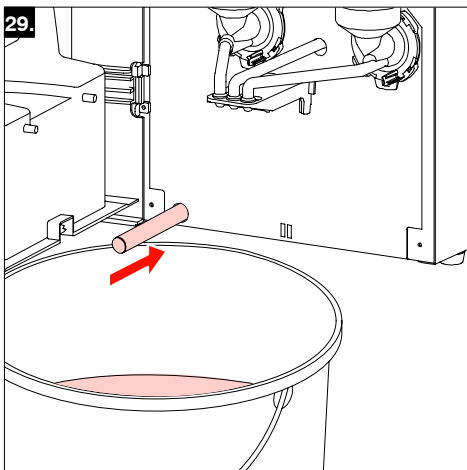
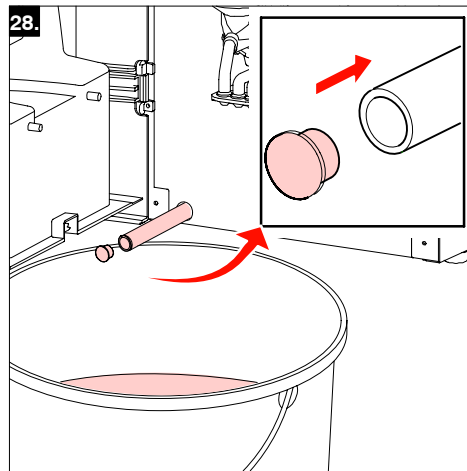
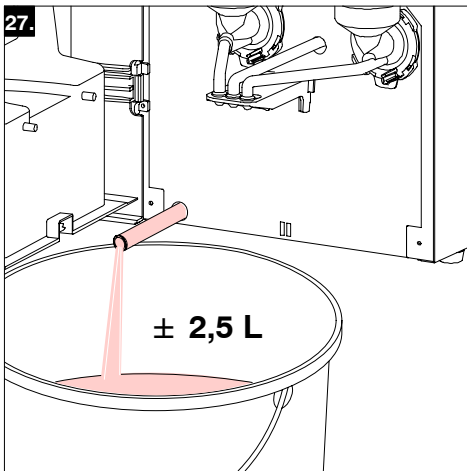
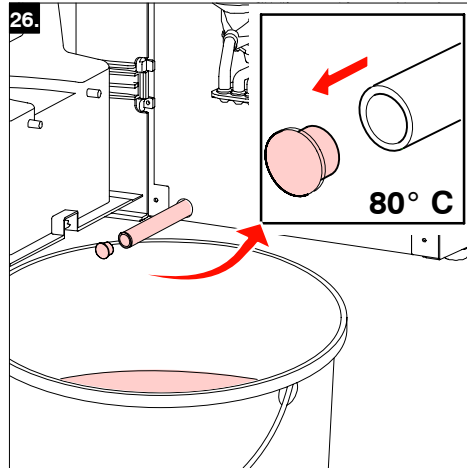
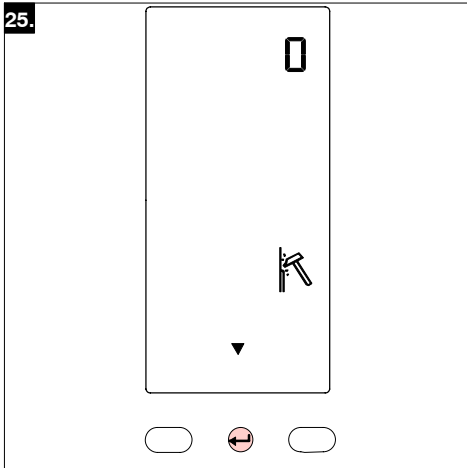

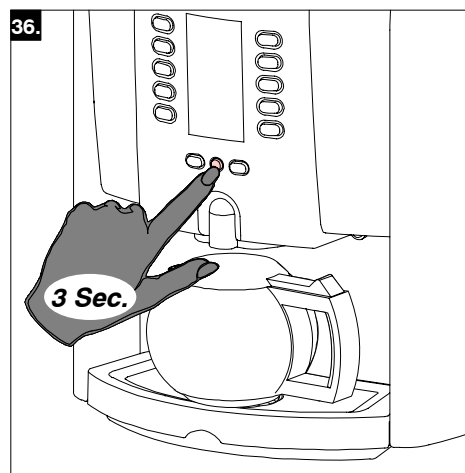
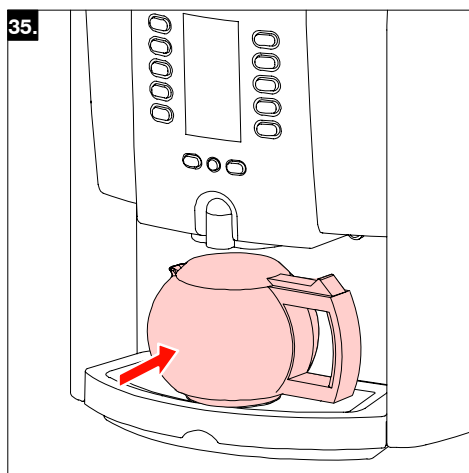
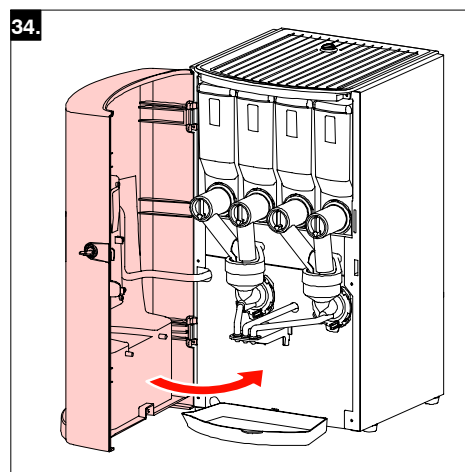
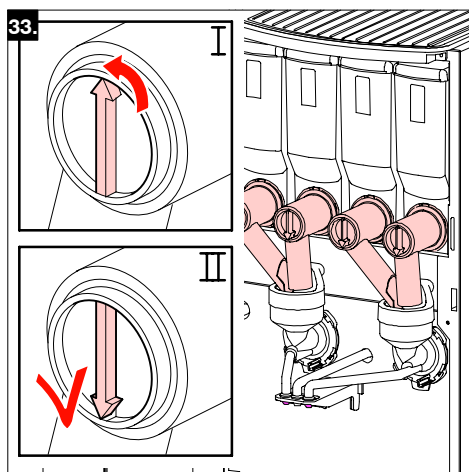
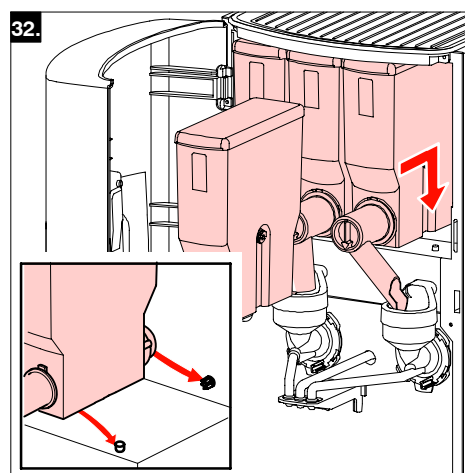
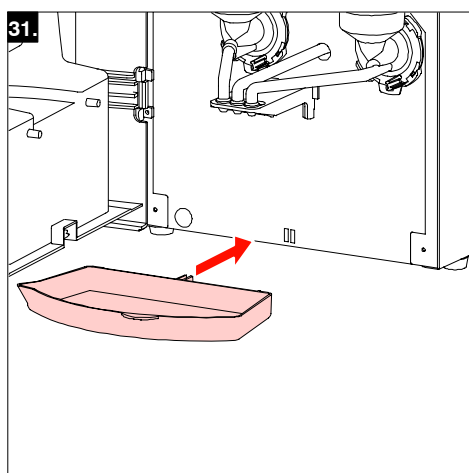
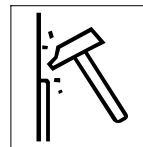



37.

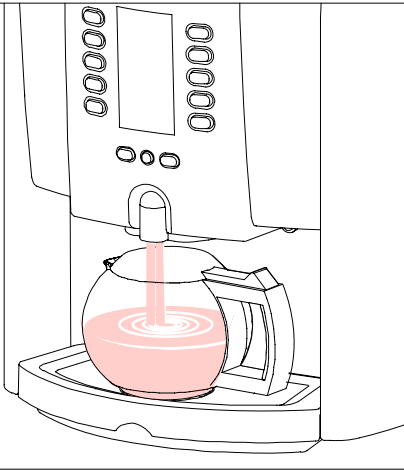

## Head office

### Bravilor Bonamat BV

Address : Pascalstraat 20  
P.O.Box : 188  
1700 AD Heerhugowaard  
The Netherlands  
Tel. : + 31 (0)72 57 51 751  
Fax : + 31 (0)72 57 51 758  
E-mail : sales@bravilor.com

### Bonamat GmbH

Adresse : Brookstieg 14  
22145 Stapelfeld  
Deutschland  
Tel. : (040) 60 823-0  
Fax : (040) 60 823-100  
E-mail : info.de@bonamat.com

### Bonamat AB.

Adresse : Viggbyholmsvägen 83  
18377 Täby  
Sverige  
Tel. : 08-622 64 50  
Fax : 08-622 58 70  
E-mail : info.se@bonamat.com

### Bravilor Ltd

Address : Unit 15 Cordwallis Park  
Clivemont Road, Maidenhead  
Berkshire SL6 7BU  
United Kingdom  
Tel. : (01628 )- 776060  
Fax : (01628) - 776035  
E-mail : enquiries@bravilor.com

### Bravilor Belux N.V.

Adres : Boomgaardreef 7  
2900 Schoten  
Belgique / België  
Tel. : (03) 663.77.22  
Fax : (03) 663.77.44  
E-mail : info.be@bravilor.com

### Bonamat Norge AS

Adress : Kallerudlia 11  
Postboks : 60  
2801 Gjøvik  
Norge  
Tel. : 61 13 09 65  
Fax : 61 13 09 75  
E-mail : info.no@bonamat.com

### Bravilor France S.A.S.

Adresse : 5, Rue Michel Carré  
B.P. : N° 34  
95102 Argenteuil Cedex  
France  
Tél. : 01.34.34.47.74  
Fax : 01.34.34.47.75  
E-mail : info.fr@bravilor.com





Italiano  
Ελληνικά  
Česky  
Polski  
Română

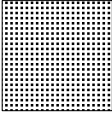

Русский  
Türkçe  
中文  
日本語  
한글

Informazione Πληροφορίες Informace Informacja Informație		Информация Bilgi 資料 情報 알림
Indice Περιεχόμενα Obsah Spis treści Index		Содержание İçindekiler 内容目録 目次 복차
Installazione Εγκατάσταση Instalace Instalacja Operare		Установка Yerleştirme 安裝 設置 설치
Decalcificazione Αφαλάτωση Odvápnění Odkamienianie Decalcarizare		устка от накипи Kireçten arındırma 除垢 デスケール 스케일 청소
Programmazione Προγραμματισμός λειτουργίας Programování Programowanie Programare		Программирование Programlama 程式 プログラミング 프로그램
Prescrizioni di sicurezza Έντυπο ασφαλείας Bezpečnostní kniha Wskazówki bezpieczeństwa Carte instructaj		Инструкция по эксплуатации Güvenlik kitabı 安全冊子 安全說明書 안전 지침서
Manuale per l'utente Εγχειρίδιο χρήσης Provozní příručka Instrukcja obsługi Manualul utilizatorului		Руководство пользователя Kullanıcı kılavuzu 使用者手冊 ユーザーマニュアル 카트리지

Elenco prodotti Πίνακας συστατικών Přehled směsí Lista skłódników Listă ingrediente		Список ингредиентов İçindekilerin listesi 成份清單 材料リスト 원재료 목록
Attendere Αναμονή Čekejte Czekaj Așteaptă		Ждите Bekle 等候 待つ 기다림
Guanti di protezione Γάντια ασφαλείας Ochranné rukavice Rękawiczki ochronne Mănuși protecție		Защитные перчатки Güvenlik eldivenleri 安全手套 安全手袋 안전용 장갑
Occhiali di protezione Γυαλιά ασφαλείας Ochranné brýle Okulary ochronne Ochelari protecție		Защитные очки Güvenlik gözlükleri 護目鏡 安全眼鏡 안전용 안경
Liquido caldo Καυτό υγρό Horký nápoj Gorący płyn Lichid fierbinte		Горячая жидкость Sıcak sıvı 熱液體 熱水 너운 용액
Contatore Μετρητής Počítadlo Licznik Contor		СРетРик Sayaç 計數器 カウンタ 카운터
Accessori Εξαρτήματα Příslušenství Akcesoria Accesorii		Аксессуары Aksesuarlar 附件 備品 악세서리
Opzione Προαιρετικό Nevolinný Opcja Opțional		Необязательный Opsiyonel 選擇 オプション 선택 사양



**/// BRAVILOR  
BONAMAT**

© 07-2006

700.403.429A